

Air Conditioning, Refrigeration, Plumbing, Heating, Automotive and Maintenance

HVAC/R & PLUMBING EQUIPMENT CATALOG

FOR U.S. JOBS



QUALITY TOOLS THAT GO TO WORK WITH YOU®



SINCE 1949



UNIWELD PRODUCTS, INC. FORT LAUDERDALE, FL 33312 U.S.A.



Since 1949, Uniweld, a U.S. Manufacturer, has employed over 300 workers who help design, manufacture, and distribute U.S. made products to be sold worldwide! As we celebrate 65 years of manufacturing excellence, our focus is ever set on the future to provide a superior product coupled with unmatched customer service. Uniweld's World Headquarters and manufacturing facility based in Ft. Lauderdale, FL has state of the art robotic CNC machines that produce quality flame tools, accessories, and pressure gauges for the air conditioning, refrigeration, plumbing, heating, automotive and maintenance industries. We thank you for supporting Uniweld Products...

"QUALITY TOOLS THAT GOES TO WORK WITH YOU!"

New Products

FOR U.S. JOBS
UNIWELED EMPLOYES OVER 300 WORKERS



USAM SPIRIT™ Manifold
R-410A/R-22/R-404A/R-134a
(see page 52)



RHP800
Nitrogen Regulator
(see page 79)



EZ TURN
EZ Turn Anti-Blowback
Fitting
(see page 71)



NV1 Nitrovue
Nitrogen Flow Indicator
(see page 78)



UTC701
Mini
Tubing Cutter
1/8" to 1" O.D.
(see page 86)

UTC704
Premium
Tubing Cutter
1/8" to 1 3/4" O.D.
(see page 87)





Introduction to Flame Tools

OVER 80% OF UNIWELD PRODUCTS ARE MADE IN THE USA



BRAZING



SOLDERING



CUTTING



WELDING

This catalog provides you with detailed information on a full range of Uniweld flame tools for the HVAC/R , Plumbing, Automotive and Industrial Maintenance professionals. When deciding on what flame tools are needed for your particular job application, it's a good idea to determine, "Will it be used specifically for welding or cutting steel, soldering or brazing copper tubing or should it be a multi-purpose outfit." We've provided the basic industry definitions for the above applications to help you decide what flame tools will be required to get the job done efficiently.

★ WELDING

Welding is the joining of similar metals by heating until molten and then fusing them together, usually with a similar filler material.

★ CUTTING

Cutting occurs when steel is heated to a pasty range (over 1600°F) and a jet of Oxygen is added into this heated area causing it to rapidly oxidize and separate.

★ SOLDERING & BRAZING

Basically, they're both very similar. It is the joining of metals through the use of heat and a filler metal. The difference between soldering and brazing is the temperature at which the filler material melts. If it melts below 800°F, it is soldering; above 800°F, it is brazing. In general, soldering will provide a permanent bond while brazing is preferred when vibration, temperature and higher tensile strength are considerations.

FIRE TRIANGLE

Fire consists of three basic elements. 1. Fuel; 2. Oxygen; 3. Ignition. This is called the Fire Triangle.

OXYACETYLENE

Combining Oxygen and Acetylene from two separate tanks produces a concentrated flame of approx. 5600°F, that is ideal for brazing copper tube, welding and cutting steel and general maintenance repairs. This type of flame tool is preferred by HVAC/R tradesmen because of its hot, concentrated flame with low heat transfer into sensitive components. Heat transfer is minimized with the use of proper tips.

AIR/ACETYLENE

These flame tools use a single tank of fuel and by induction of the outside air create an efficient flame. The target heat is 2700°F and is ideally suited for soldering and brazing copper tube. Tank size is usually a B (40 cu.ft.) or MC (10 cu.ft.)

AIR/LP GAS

These flame tools utilize a single tank of liquid petroleum fuel and by induction of the outside air create a flame. The most common LP fuels are Propane and MAP//Pro™ (Propylene). The target heat for Propane is 1750°F and for MAP//Pro™ it's 2400°F.





Table of Contents

1 Oxyacetylene



- 1 Introduction to Flame Tools
- 4-5 Mastar® Outfits
- 6-7 Cap'n Hook® Outfits
- 8-11 Patriot® Outfits
- 12-13 Centurion® Outfits
- 14 Cutting Attachments/Welding Handles
- 15 Oxyacetylene Operating Procedures and Safety Posters
- 16 Welding, Brazing and Cutting Tips
- 17 Rosebud Heating Tips and Flexible Brazing Tips
- 18 Tuning Fork® Tip and Micro 6000™ Miniature Tips
- 19 Cap'n Hook® High Performance Tips

4 Parts Accessories



- 34 Air Fuel Handles and Adaptors
- 35 Hoses: Single and Twin
- 36 Patriot® Series Regulators and Oxy/Fuel Adaptor
- 37 Mastar® and Centurion® Series Regulators and Replacement Gauges
- 38 CGA Cylinder Valve Connections
- 39 Adaptors and Hose Fittings
- 40 Cylinders, Tanks and Test Gauges
- 41 Carrying Stands and Cylinder Trucks
- 42 Accessories, Combination Wrenches, Goggles and Tip Cleaners
- 43 Flint Lighters, Plastic Tool Box
- 44 Flashback Arrestors and Check Valves
- 45 Cool Blue® Paste, Flame Barrier, Heat Guard

2 Air/Acetylene



- 20-21 Twister® 2 Self Igniting Tips and Kits
- 22 Twister® Tips
- 23 Twister® Kits and Components
- 24 Thruster® Kits and Components
- 25 Soft Flame Kits and Components
- 26 Specialty Tips

5 HVAC/R Tools



- 46 Humm-Vac® Vacuum Pumps
- 47 5.5 CFM and 1.5 CFM Vacuum Pumps
- 48 Vacuum Pump Replacement Parts and Vacuum Pump Oil
- 49 MaxEvac™ Kit and Valve Core Removal Kits
- 50 Electronic Refrigerant Scale
- 51 Vapor-Vue® A/C Flush Kit and Actuating Valve
- 52 Manifolds, SPIRIT Two-Valve Aluminum: R-410A/R-22/R-404A/R-134a
- 53 Manifolds, Four Valve Aluminum: R-410A/R-22/R-404A/R-134a
- 54 Manifolds, Two Valve Brass: 3/8" Gauges R-410A/R-22/R-404A/R-134a
- 55-56 Manifolds, Two Valve Brass: 2 1/2" Gauges R-22/R-404A/R134a

3 Air/LP



- 27 Twister® Kits and Tips
- 28 Thruster® Kits and Tips
- 29 Thruster® Swivl-IT Kits/Weed Burner
- 30 Pencil Point Flame Kits
- 31 Heat Shrink Kits/Tips
- 32 Hand Torches
- 33 Self-Igniting Hand Torches





Table of Contents

5 HVAC/R Tools

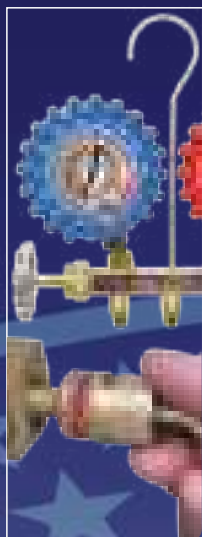

- 57 Manifold Replacement Parts
- 58-59 NPF® and LPF™ Manifold Gauges
- 60 Soft Magic® Barrier Hose with Standard Fittings
- 61 Soft Magic® Barrier Hose with EZ-Turn Anti-Blowback Fittings
- 62 Soft Magic® Barrier Ball Valve Hoses
- 63 Ball Valve Adaptors and 6" Hoses
- 64 Soft Magic® Heavy Duty Vacuum and Charging Hoses
- 65 Super Black Magic® Refrigerant Hoses
- 66 Adaptors and Accessories
- 67 Propane Halide Leak Detector

8 Tubing Tools



- 80 PVC Pipe Cutters
- 81 Ratchet Screwdrivers
- 82 Reversible and Offset Ratchet Wrenches
- 83 Deburring Tools/Pinchoff Tool
- 84 Heavy Duty Flaring Tools
- 85 Flaring and Swaging Tools
- 86-87 Premium Heavy Duty Tube Cutters
- 88 Standard and Mini Tubing Cutters
- 89 Quick Action Tubing Cutters
- 90 Ratchet Tube Bender
- 91 3-in-1 Triple Tube Bender/Lever Benders

6 Automotive A/C

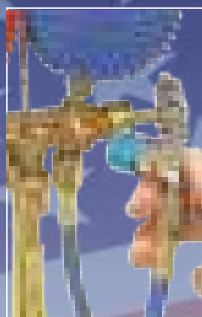

- 68-69 R134a Automotive Manifold, Two Valve Brass and Aluminum
- 70 R134a Automotive Charging Hoses
- 71 R134a Automotive Service Couplers and Conversion Kits
- 72 Automotive A/C Flush Kit and Can Tap Valve
- 73 Automotive Oil/Dye Injector and A/C Adaptor Kit

9 Gauges/Thermometers



- 92 Gas Pressure Test Kit and Water Manometer
- 93 Tridicator Gauges and Bi-Metal Thermometers
- 94 Gas and Water Test Gauges
- 95 Utility Gauges
- 96 Liquid Filled Gauges
- 97 Replacement Welding Gauges/Lenses

7 Nitrogen, Air & CO₂



- 74 Nitrogen Sludge Sucker®/Blaster® Kits
- 75 Sludge Sucker®, Maintenance and Accessory Kit
- 76 Sludge Sucker® Sludge Blaster and Drain Blaster
- 77 Blowgun, Blowgun Accessories, Rubber Plug Adaptors
- 78 NitroVue Nitrogen Flow Indicator
- 79 Nitrogen/CO₂ Regulators and Replacement Gauges

10 Alloys



- 98 Aluminum Soft Solder Repair Kits
- 99 Silver Solder, Low Fuming Bronze Flux
- 99 Uni-Brite Silver Solder and Uni-1500FC Flux Coated Brazing Rod

General Information

- 100-106 Part Number Index
- 107 Uniweld Contact Information
- 108 NATE Flame Tool Safety Training
- 109-112 Marketing Sales/Aids



Ranked #1 for Commercial Refrigeration Technicians



Mastar® Outfits

FOR U.S. JOBS
UNIWELD EMPLOYS OVER 300 WORKERS

Highly rated by commercial refrigeration technicians, Mastar® outfits contain all the necessary top of the line components for welding, cutting and brazing.

1 Oxyacetylene



- Industrial grade Mastar® series regulators with protective rubber gauge boots
- Rear valve welding handle with stainless steel ball point valves for accurate gas control
- Cutting attachment with one-piece solid copper mixer that cuts up to 1/2" steel with supplied cutting tip
- Rosebud tip for brazing up to 2 5/8" copper tubing
- Welding tip for brazing up to 1" copper tubing and welding up to 1/8" steel

KL550-TR



KL550-4P-T

- C = Metal Carrying Stand
- C-T = Metal Carrying Stand & Tanks
- P = Plastic Carrying Stand
- P-T = Plastic Carrying Stand & Tanks
- TR = Metal Hand Truck w/Wheels

Additional outfit options listed below include a variety of carrying stands and tanks*. Optional tips expand capabilities. See pages 16-19

	Part#	UPC#	Welding HanDrillsdle	Welding/ Brazing Tip	Rosebud Heating Tip	Cutting Attachment	Cutting Tip	Oxygen Regulator	Acetylene Regulator	Carrying Stand	Tanks*
Outfits	KL550-4	82200			Type17-15		5-101-0D	RS0	RSMC2	w/o	w/o
	KL550-4C	82201			Type17-15		5-101-0D	RS0	RSMC2	500S	w/o
	KL550-4C-T	82202			Type17-15		5-101-0D	RS0	RSMC2	500S	MC/R
	KL550-4P	82205	WH550	Type17-2	Type17-15	CA550	5-101-0D	RS0	RSMC2	511	w/o
	KL550-4P-T	82206			Type17-15		5-101-0D	RS0	RSMC2	511	MC/R
	KL550-5	82207			Type17-15		5-101-0D	RS0	RSB2	w/o	w/o
	KL550-TR	82208			w/o		5-101-2D	RS0	RSB2	504	w/o
	KL555-TR	82259			w/o		5-101-2D12106 [psi/kg]	12107 [psi/kg]		504	w/o

Outfits Include: H32A [12.5] ft. Twin Hose, WG53 Goggles, FL34 Flint Lighter, W05 Tank Key w/chain.

*Tanks Shipped Empty



For Maintenance/Service Technicians



Mastar® Outfits

FOR U.S. JOBS
UNIWELD EMPLOYS OVER 300 WORKERS

This premium outfit includes all the components of the Mastar® outfit on page 4, plus an air/fuel adaptor that modifies the welding handle to be used with any of Uniweld's efficient quick connect air/acetylene tips.



KLT550-4

- Industrial grade Mastar® series regulators with protective rubber gauge boots
- Rear valve welding handle with stainless steel ball point valves for accurate gas control
- Cutting attachment with one-piece solid copper mixer that cuts up to 1/2" steel with supplied cutting tip. Optional cutting tips available for cutting up to 2" steel
- Rosebud tip for brazing up to 2 5/8" copper tubing
- Welding tip for brazing up to 1" copper tubing and welding up to 1/8" steel
- Twister® air/acetylene tip for plumbing and repair work



KLT550-4C-T

Additional outfit options listed below include a variety of carrying stands and tanks*. Optional tips expand capabilities. See pages 16-19

C = Metal Carrying Stand

C-T = Metal Carrying Stand & Tanks

P = Plastic Carrying Stand

P-T = Plastic Carrying Stand & Tanks

TR = Metal Hand Truck w/Wheels

	Part#	UPC#	Welding Handle	Welding/ Brazing and Heating Tip	Acetylene Tip	Adaptor	Cutting Attachment	Cutting Tip	Oxygen Regulator	Acetylene Regulator	Carrying Stand	Tanks*
Outfits	KLT550-4	82210								RSMC2	w/o	w/o
	KLT550-4C	82211								RSMC2	500S	w/o
	KLT550-4C-T	82212		Type17-2	A-8 Twister® Air/Fuel Tip	F13 Air/Fuel Adaptor	CA550	5-101-0D	RSO	RSMC2	500S	MC/R
	KLT550-4P	82215	WH550	Type17-15						RSMC2	511	w/o
	KLT550-4P-T	82216								RSMC2	511	MC/R
	KLT550-5	82217								RSB2	w/o	w/o
	KLT550-5TR	82218								RSB2	504	w/o

Outfits Include: H32A [12.5] Twin Hose, WG53 Goggles, FL34 Flint Lighter, W05 Tank Key w/chain.

*Tanks Shipped Empty



Uniweld Products, Inc. Fort Lauderdale, FL 33312 U.S.A. Customer Service: 800.323.2111
info@uniweld.com • www.uniweld.com

Premium Outfits for Welding and Brazing



Cap'n Hook® Outfits

FOR U.S. JOBS
UNIWELD EMPLOYS OVER 300 WORKERS

Premium portable outfits featuring Uniweld's popular patented Cap'n Hook® five flame tip for 100% wraparound brazing heat. Ideal for HVAC/R technicians and plumbers.

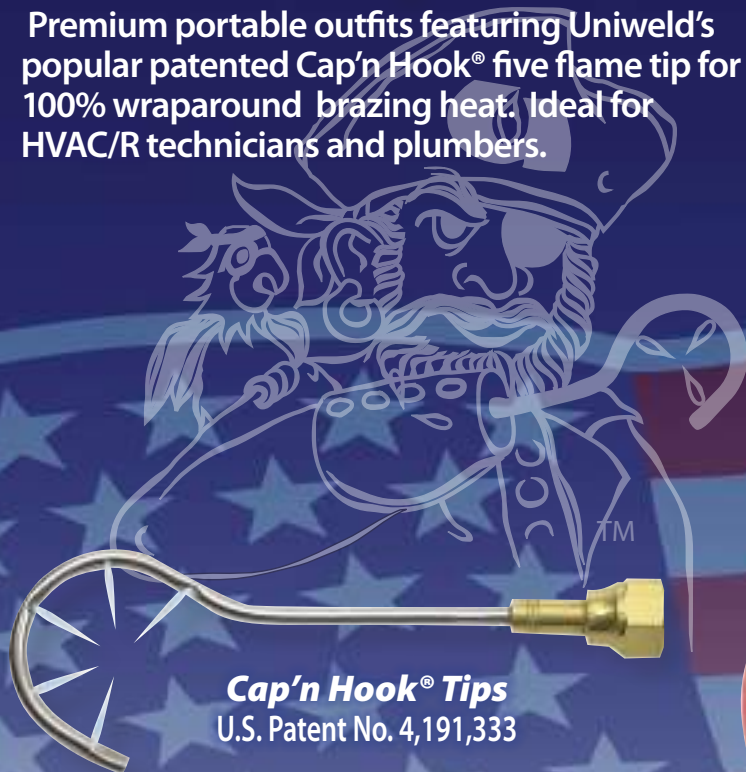

Cap'n Hook® Tips
U.S. Patent No. 4,191,333

- Single stage Patriot® series regulators with protective rubber gauge boots
- Front valve welding handle with stainless steel ball point valves for accurate gas control
- Welding tip for brazing up to 1" copper tubing and welding up to 1/8" steel
- NEW & Improved Cap'n Hook® 5 flame tip for brazing up to 1" copper tubing



K22P-T

Additional outfit options listed below include a variety of carrying stands and tanks*. Optional tips expand capabilities. See pages 16-19

C = Metal Carrying Stand
C-T = Metal Carrying Stand & Tanks
P = Plastic Carrying Stand
P-T = Plastic Carrying Stand & Tanks



	Part#	UPC#	Welding Handle	Welding/Brazing Tip	Oxygen Regulator	Acetylene Regulator	Carrying Stand	Tanks*
Cap'n Hook® Outfits	K22	82339					w/o	w/o
	K22C	82340		Type17-2			500S	w/o
	K22C-T	82341	71	MTF-5	RO	RMC2	500S	MC/R
	K22P	82344		Cap'n Hook® Tip			511	w/o
	K22P-T	82345					511	MC/R

Outfits Include: H32A [12.5 ft.] Twin Hose, WG53 Goggles, FL34 Flint Lighter, W05 Tank Key w/chain.

*Tanks Shipped Empty





Premium Outfits for Cutting, Welding and Brazing

Cap'n Hook® Outfits

FOR U.S. JOBS
UNIWELD EMPLOYS OVER 300 WORKERS

A cutting attachment and cutting tip have been added to the Cap'n Hook® outfit on page 6. You now have the added ability of cutting up to 1/2" steel with the supplied tip. The Cap'n Hook® five flame tip provides a stable, wraparound flame.

KL22C-T

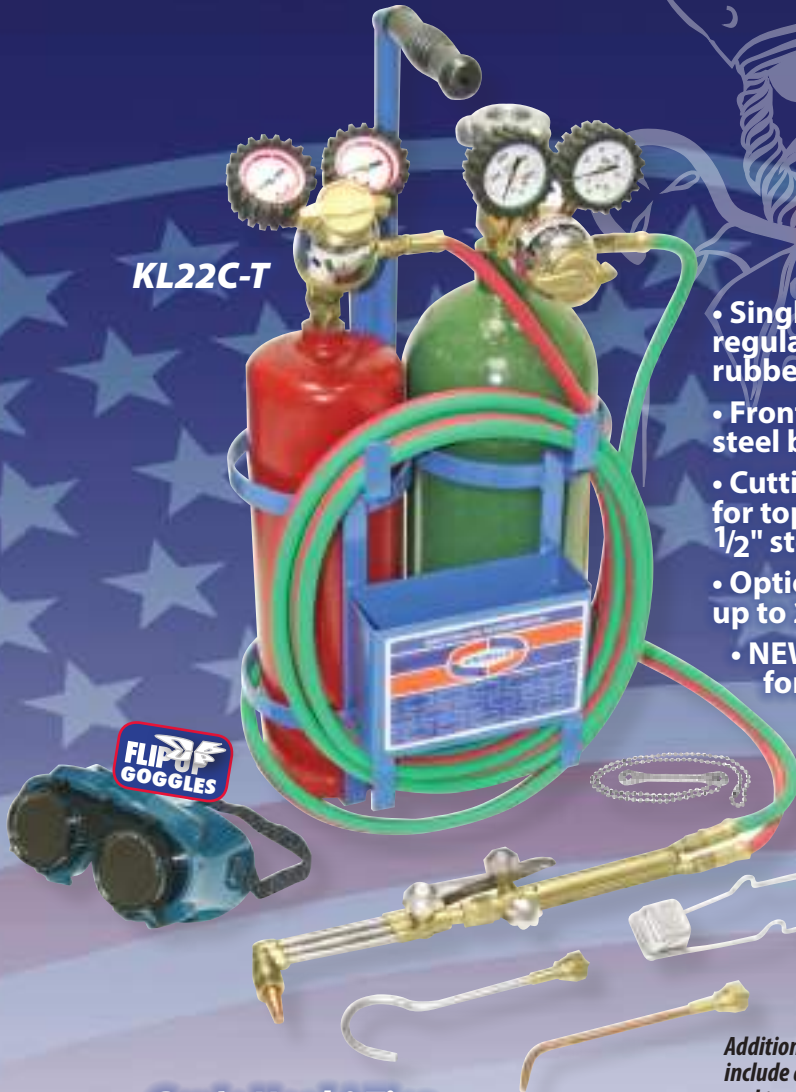

- Single stage Patriot® series regulators with protective rubber gauge boots
- Front valve welding handle with stainless steel ball point valves for accurate gas control
- Cutting attachment with three tube tip mix for top performance and safety that cuts up to 1/2" steel with supplied tip
- Optional cutting tips available for cutting up to 2" steel
- NEW & Improved Cap'n Hook® 5 flame tip for brazing up to 1" copper tubing
- Welding tip for brazing up to 1" copper tubing and welding up to 1/8" steel



KL22



Cap'n Hook® Tips
U.S. Patent No. 4,191,333

Additional outfit options listed below include a variety of carrying stands and tanks*. Optional tips expand capabilities. See pages 16-19

C = Metal Carrying Stand
C-T = Metal Carrying Stand & Tanks
P = Plastic Carrying Stand
P-T = Plastic Carrying Stand & Tanks

	Part#	UPC#	Welding Handle	Welding Brazing Tip	Cutting Attachment	Cutting Tip	Oxygen Regulator	Acetylene Regulator	Carrying Stand	Tanks*
Cap'n Hook® Outfits	KL22	82500							w/o	w/o
	KL22C	82501		Type17-2					500S	w/o
	KL22C-T	82502	71	MTF-5	CA100	CT100-0D	R0	RMC2	500S	MC/R
	KL22P	82505		Cap'n Hook® Tip					511	w/o
	KL22P-T	82506							511	MC/R

Outfits Include: H32A [12.5 ft.] Twin Hose, WG53 Goggles, FL34 Flint Lighter, W05 Tank Key w/chain.

*Tanks Shipped Empty



Uniweild Products, Inc. Fort Lauderdale, FL 33312 U.S.A. Customer Service: 800.323.2111
info@uniweild.com • www.uniweild.com

Tech favorite for Welding, Brazing and Cutting



Patriot® Outfits

FOR U.S. JOBS
UNIWELD EMPLOYS OVER 300 WORKERS

A favorite choice of Refrigeration and HVAC/R Service Technicians. Three different size welding tips come complete with elbow mixer and nut.

1 Oxyacetylene



KL71-4C-T

- Single stage Patriot® series regulators with protective rubber gauge boots
- Front valve welding handle with stainless steel ball point valves for accurate gas control
- Three tube tip mix cutting attachment for top performance and safety; cuts up to 1/2" steel with supplied cutting tip
- Optional cutting tips available for cutting up to 2" steel
- Three welding tips for brazing from 3/16" to 1" copper tubing and welding up to 1/8" steel

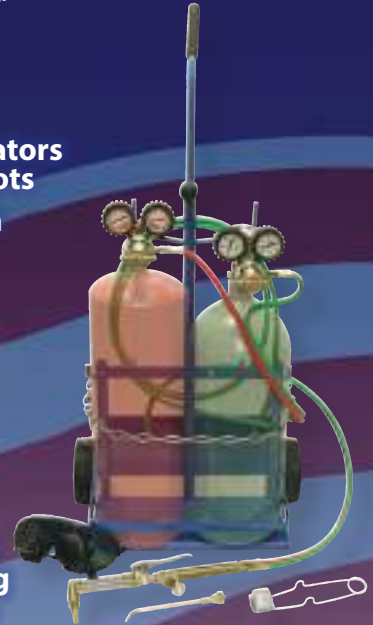

KL71-5TR



C = Metal Carrying Stand
C-T = Metal Carrying Stand & Tanks

P = Plastic Carrying Stand
P-T = Plastic Carrying Stand & Tanks



When brazing smaller copper tubing, use the proper size tip. Cutting back on the fuel and oxygen when using an oversized tip will starve the tip and may result in backfire or flashback.

Additional outfit options listed below include a variety of carrying stands and tanks*. Optional tips expand capabilities. See pages 16-19

	Part#	UPC#	Welding Handle	Welding/Brazing Tip	Cutting Attachment	Cutting Tip	Oxygen Regulator	Acetylene Regulator	Carrying Stand	Tanks*
Patriot® Outfits	KL71-4	82319						RMC2	w/o	w/o
	KL71-4C	82320						RMC2	500S	w/o
	KL71-4C-T	82321		Type17-0				RMC2	500S	MC/R
	KL71-4P	82324	71	Type17-1	CA100	CT100-0D	RO	RMC2	511	w/o
	KL71-4P-T	82325		Type17-2				RMC2	511	MC/R
	KL71-5	82326						RB2	w/o	w/o
	KL71-5TR	82336						RB2	504	w/o

Outfits Include: H32A [12.5 ft.] Twin Hose, WG53 Goggles, FL34 Flint Lighter, W05 Tank Key w/chain.

*Tanks Shipped

Maintenance Service Tech's #1 Choice



Patriot® Outfits

FOR U.S. JOBS
UNIWELD EMPLOYS OVER 300 WORKERS

Solder and braze without the use of an Oxygen cylinder when using Uniweld's Acetylene Twister® tip and air/fuel adaptor ... a real Oxygen saver!
Cuts up to 1/2" steel with supplied tip.

- Single stage Patriot® series regulators with protective rubber gauge boots
- Front valve welding handle with stainless steel ball point valves for accurate gas control
- Cutting attachment with three tube tip mix for top performance and safety. Cuts up to 1/2" steel with supplied tip
- Optional cutting tips available for cutting up to 2" steel
- Air/fuel adaptor converts welding handle to use quick connect air/fuel tips
- Welding tip for brazing up to 1" copper tubing and welding up to 1/8" steel

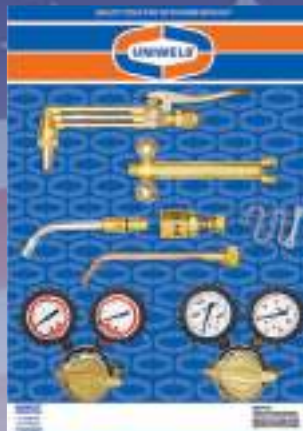

KLT71-4

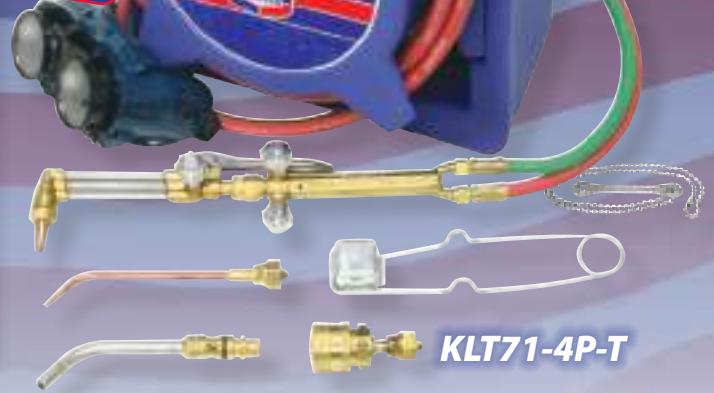

KLT71-4P-T

C = Metal Carrying Stand
C-T = Metal Carrying Stand & Tanks
P = Plastic Carrying Stand
P-T = Plastic Carrying Stand & Tanks

Additional outfit options listed below include a variety of carrying stands and tanks*. Optional tips expand capabilities. See pages 16-19

	Part#	UPC#	Welding Handle	Welding Brazing Tip	Acetylene Tip	Adaptor	Cutting Attachment	Cutting Tip	Oxygen Regulator	Acetylene Regulator	Carrying Stand	Tanks*
Patriot® Outfits	KLT71-4	82327								RMC2	w/o	w/o
	KLT71-4C	82328								RMC2	500S	w/o
	KLT71-4C-T	82329								RMC2	500S	MC/R
	KLT71-4P	82332	71	Type 17-2	A-8 Twister® Tip	F13 Air/Fuel Adaptor	CA100	CT100-0D	RO	RMC2	511	w/o
	KLT71-4P-T	82333								RMC2	511	MC/R
	KLT71-5	82334								RB2	w/o	w/o
	KLT71-5TR	82335								RB2	504	w/o

Outfits Include: H32A [12.5 ft.] Twin Hose, WG53 Goggles, FL34 Flint Lighter, W05 Tank Key w/chain.

*Tanks Shipped Empty



Uniweld Products, Inc. Fort Lauderdale, FL 33312 U.S.A. Customer Service: 800.323.2111
info@uniweld.com • www.uniweld.com



1 Oxyacetylene

Basic Welding/Brazing Outfit



Patriot® Outfits

An economical, contractor grade outfit with all the basic components for brazing and for welding. Easily portable for light to medium duty jobs.

FOR U.S. JOBS
UNIWELD EMPLOYS OVER 300 WORKERS

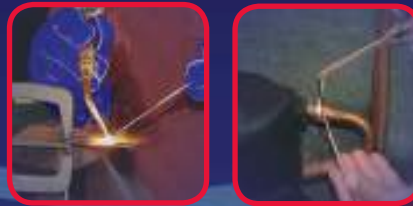
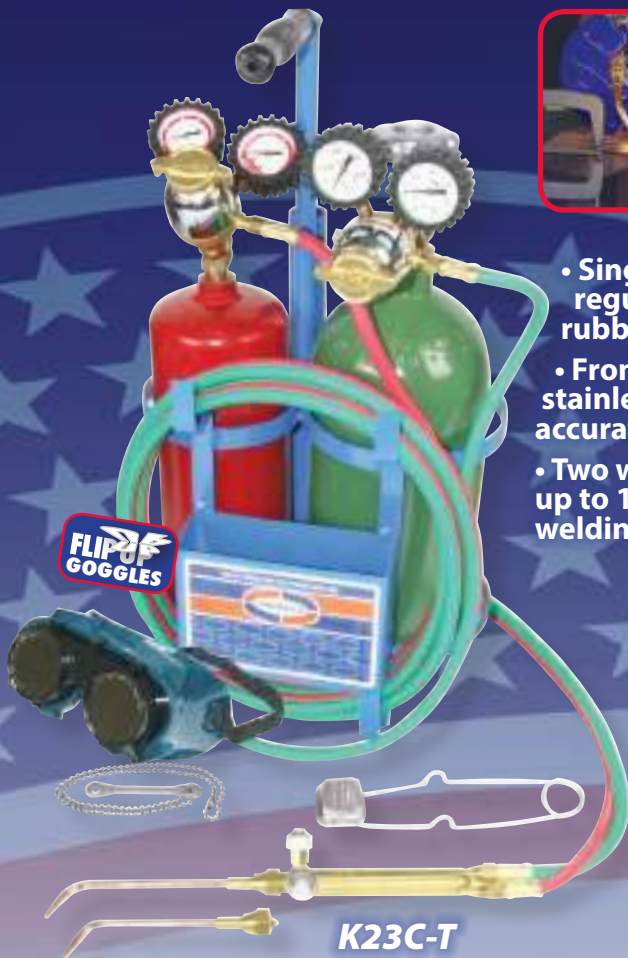

- Single stage Patriot® series regulators with protective rubber gauge boots
- Front valve welding handle with stainless steel ball point valve for accurate gas control
- Two welding tip sizes for brazing up to 1" copper tubing and for welding up to 1/8" steel



K24TB

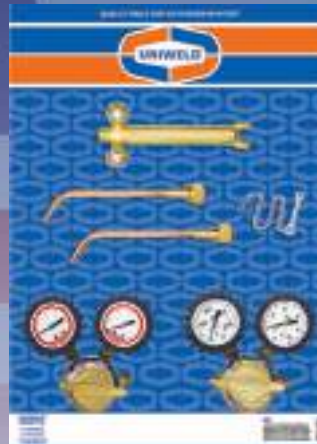

K23

C = Metal Carrying Stand
C-T = Metal Carrying Stand & Tanks
P = Plastic Carrying Stand
P-T = Plastic Carrying Stand & Tanks

Additional outfit options listed below include a variety of carrying stands and tanks*. Optional tips expand capabilities. See pages 16-19

	Part#	UPC#	Welding Handle	Welding Brazing Tip	Oxygen Regulator	Acetylene Regulator	Carrying Stand	Tanks*
Patriot® Outfits	K23	82300				RMC2	w/o	w/o
	K23C	82301				RMC2	500S	w/o
	K23C-T	82302		Type17-0		RMC2	500S	MC/R
	K23P	82305	71	Type17-2	R0	RMC2	511	w/o
	K23P-T	82306				RMC2	511	MC/R
	K24	82307				RB2	w/o	w/o
	K24TB	82308				RB2	503	w/o

Outfits Include: H32A [12.5 ft.] Twin Hose, WG53 Goggles, FL34 Flint Lighter, W05 Tank Key w/chain. *Tanks Shipped Empty



Welding/Brazing + Cutting Upgrade



Patriot® Outfits

FOR U.S. JOBS
UNIWELD EMPLOYS OVER 300 WORKERS

A cutting attachment and cutting tip have been added to upgrade the capabilities of the contractor outfits available for use with Acetylene Propane or MAP//Pro® [Propylene].

- Single stage Patriot® series regulators with protective rubber gauge boots
- Front valve welding handle with stainless steel ball point valves for accurate gas control
- Cutting attachment with three tube tip mix for top performance and safety. Cuts up to 1/2" steel with supplied tip
- Optional cutting tips available for cutting up to 2" steel
- Welding tip for brazing up to 1" copper tubing and welding up to 1/8" steel



K55CM



K46P-T

C = Metal Carrying Stand
C-T = Metal Carrying Stand & Tanks
P = Plastic Carrying Stand
P-T = Plastic Carrying Stand & Tanks

Additional outfit options listed below include a variety of carrying stands and tanks*. Optional tips expand capabilities. See pages 16-19

		Part#	UPC#	Welding Handle	Welding/Brazing Tip	Cutting Attachment	Cutting Tip	Oxygen Regulator	Fuel Gas Regulator	Carrying Stand	Tanks*
Patriot® Outfits	Acetylene	K46P	82311	71	Type17-2	CA100	CT100-0D	RO	RMC2	511	w/o
		K46P-T	82312				CT100-0D		RMC2	511	MC/R
		K56C	82313				CT100-0D		RMC2	500S	w/o
		K56C-T	82314				CT100-0D		RMC2	500S	MC/R
	MAP//Pro™ [Propylene]	K45CM	82315	Type17-3	CA550	5-200M-0D†	RP3A	511	w/o		
		K55CM	82316			5-200M-0D†	RP3A	510	w/o		
		Propane	K45CP			82317	5-200-0D~	RP3A	511	w/o	
			K55CP			82318	5-200-0D~	RP3A	510	w/o	

Outfits Include: H32A [12.5 ft.] Twin Hose, WG53 Goggles, FL34 Flint Lighter, W05 Tank Key w/chain †MAP//Pro™ ~Propane. *Tanks Shipped Empty.



Uniweld Products, Inc. Fort Lauderdale, FL 33312 U.S.A. Customer Service: 800.323.2111
info@uniweld.com • www.uniweld.com



Basic Welding/Brazing Outfit

Centurion® Outfits

FOR U.S. JOBS
UNIWELD EMPLOYS OVER 300 WORKERS

An economical, contractor grade outfit with all the basic components for brazing and for welding. Easily portable for light to medium duty jobs.



- Single stage Centurion® series regulators with rubber protective gauge boots
- Front valve welding handle with stainless steel ball point valve for accurate gas control
- Two welding tip sizes for brazing up to 1" copper tubing and for welding up to 1/8" steel
- Optional welding/brazing tips expand capabilities. See pages 16-19



KC100CT



KC100FC

C = Metal Carrying Stand
C-T = Metal Carrying Stand & Tanks
P = Plastic Carrying Stand
P-T = Plastic Carrying Stand & Tanks

Additional outfit options listed below include a variety of carrying stands and tanks*.

	Part#	UPC#	Welding Handle	Welding/Brazing Tip	Cap'n Hook® Tip	Micro 6000™ Specialty Tips	Oxygen Regulator	Acetylene Regulator	Carrying Stand	Tanks*
Centurion® Outfits	KC100	82607	71	Type17-0 Type17-2			R0100	RMC100	w/o	w/o
	KC100C	82601							500S	w/o
	KC100CT	82602							500S	MC/R
	KC100P	82603							511	w/o
	KC100PT	82604		511					MC/R	
	KC122P	82621							511	w/o
	KC122L	82620							w/o	w/o
	KC100FC†	82609		Type17-3						R0100

Outfits Include: H32A [12.5 ft.] Twin Hose, WG53 Goggles, FL34 Flint Lighter, W05 Tank Key w/chain. *Tanks Shipped Empty
† KC100FC - Outfit Includes: H32AT [12.5 ft.] 3/16" Grade "T" Twin Hose, WG53 Goggles, FL34 Flint Lighter





Welding/Brazing + Cutting Upgrade

Centurion® Outfits

FOR U.S. JOBS
UNIWELD EMPLOYS OVER 300 WORKERS

A cutting attachment and cutting tip have been added to upgrade the economical Centurion® contractor grade outfit. Portable, lightweight and suitable for light to medium duty cutting, welding and brazing jobs.

- Single stage Centurion® series regulators with protective rubber gauge boots
- Front valve welding handle with stainless steel ball point valves for accurate gas control
- Cutting attachment with three tube tip mix for top performance and safety. Cuts up to 1/2" steel with supplied tip
- Optional cutting tips available for cutting up to 2" steel
- Welding tip for brazing up to 1" copper tubing and welding (with Acetylene) up to 1/8" steel
- Optional welding/brazing tips expand capabilities. See pages 16-19

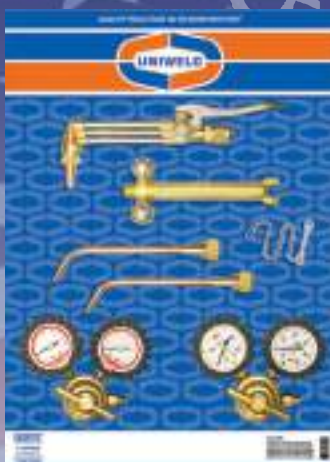

KLC100



C = Metal Carrying Stand
C-T = Metal Carrying Stand & Tanks
P = Plastic Carrying Stand
P-T = Plastic Carrying Stand & Tanks



KLC100PT

Additional outfit options listed below include a variety of carrying stands and tanks*. Optional tips expand capabilities. See pages 16-19

	Part#	UPC#	Welding Handle	Welding Brazing Tip	Cutting Attachment	Cutting Tip	Oxygen Regulator	Acetylene Regulator	Carrying Stand	Tanks*
Centurion® Outfits	KLC100	82700							w/o	w/o
	KLC100C	82701		Type17-0					500S	w/o
	KLC100CT	82702	71	Type17-2	CA100	CT100-0D	R0100	RMC100	500S	MC/R
	KLC100P	82703							511	w/o
	KLC100PT	82704							511	MC/R

Outfits Include: H32A [12.5 ft.] Twin Hose, WG53 Goggles, FL34 Flint Lighter, W05 Tank Key w/chain.

*Tanks Shipped Empty

1 Oxyacetylene



Oxyacetylene Welding & Cutting



Handles/Attachments

FOR U.S. JOBS
UNIWELD EMPLOYS OVER 300 WORKERS

1 Oxyacetylene

Uniweld's V-style CA550 cutting attachment is designed so that the oxygen and fuel gas mix in the bottom tube and flow to the tip along with the cutting oxygen flowing to the tip in the top tube. The CA100 A-style cutting attachment is designed so that the oxygen and fuel gas mix in the cutting tip for top performance and operator safety. Both style cutting attachments fit either the Uniweld 71 or WH550 welding handle. The 71 handle utilizes a front valve design while the WH550 handle features accurate rear valve gas and oxygen controls.



WH550



71



CA100

CA550

F11



F11 ADAPTOR
Adaptor converts the 71 and WH550 welding handles to use screw connect air/fuel tips for brazing and soldering without the use of an Oxygen cylinder.



F13



F13 ADAPTOR
Adaptor converts the 71 and WH550 welding handles to use quick connect air/fuel tips for brazing and soldering without the use of an Oxygen cylinder.



PUA

PUA ADAPTOR
Prest-O-Lite® tips to fit Uniweld welding handle.



UPA

UPA ADAPTOR
Uniweld tips to fit Prest-O-Lite® welding handle.

	Part#	UPC#	Head Angle	Head Type	Length	Weight	"A" Hose Connection
Cutting Attachments	CA550*	02600	90°	Forged	8"	15 oz.	-
	CA100	02700			7"	10.8 oz.	-
Welding Handles	71*	00300	-	-	6"	6.4 oz.	3/8"-24RH, Oxygen 3/8"-24LH, Fuel Gas
	WH550*	00550	-	-	8.5"	12.6 oz.	

* UL Listed



It Pays to Pay Attention in the Work Place



Play it Safe®

Always use the proper size tip for the job. Never use an oversized tip and then cut the fuel and oxygen back to work on a small job. This will starve the tip of oxygen and acetylene, resulting in improper operating pressure that may cause tip damage, overheating, backfire and flashback.

The following is a good example of proper procedure for lighting an oxyacetylene tip. This operating procedure is not a substitute for carefully reading the manufacturer's operating instructions before use.

[STEP 1] Prior to opening the cylinder valve, make sure the regulator pressure adjusting screw is backed all the way out by turning it counterclockwise until there is no pressure on the spring. When opening [or closing] the cylinder valve, always stand to the side of the cylinder with the regulator facing forward. The oxygen cylinder valve should be "cracked" open slowly until the cylinder contents gauge stops moving. Then, open the valve sufficiently to provide adequate flow. The fuel gas [acetylene] cylinder valve should be opened a maximum of $\frac{3}{4}$ turn and a wrench should remain in position on the stem of the valve while the cylinder is in use so that the valve can be quickly turned off in case of an emergency.



3A



[STEP 3] To light the tip, **open the fuel gas [acetylene] valve first about $\frac{1}{2}$ turn** and quickly ignite with a spark lighter. Adjust the flame so that it is not separated from the tip end. The flame should be bright yellow with no black soot [3A]. If necessary, increase the fuel to clear the black soot.

3B



Next, open the oxygen and adjust the flow until the white feathers disappear into a well-defined bullet nose cone called the neutral flame [3B].

[STEP 2] After the proper tip has been selected and installed, the proper operating pressure needs to be determined from the manufacturer's tip chart. Set each regulator's tip chart. Set each regulator to its corresponding pressure by adjusting the pressure adjusting screw. Purge hoses and equipment by briefly opening and closing the oxygen valve and fuel gas valve separately and venting gases safely. Purge hoses and equipment before each use.



2



4

[STEP 4] When you have completed the job and are ready to shut off the torch, **always shut the oxygen valve first and then the fuel gas valve [acetylene]**. **NOTE:** Shutting off the fuel gas first can cause backfire and/or flashback.

ASK FOR FREE! FULL-SIZE (23"x36") SAFETY POSTER WHEN PLACING YOUR NEXT ORDER



Part#USP8E
English
Safety Poster

Part#USP8S
Spanish
Safety Poster

Part#USP8F
French
Safety Poster

Part#USPA
Arabic
Safety Poster



5

[STEP 5] To shut down the torch for storage or transportation, close the cylinder valves. Release the oxygen pressure by opening the oxygen torch valve [vent safely]. Close the torch valve and repeat this same process for the fuel gas [vent safely]. Close all valves tightly and secure the equipment. **Now the shutdown is complete!**



Uniweld Products, Inc. Fort Lauderdale, FL 33312 U.S.A. Customer Service: 800.323.2111
info@uniweld.com • www.uniweld.com

15

Brazing, Welding & Cutting



Tips, Tips, Tips...

FOR U.S. JOBS
UNIWELD EMPLOYS OVER 300 WORKERS

The popular Type17 tips come complete with elbow, mixer and nut. Use with Acetylene, Propane, MAP//Pro™ [Propylene] and Natural Gas.

Type17-2

Part#	UPC#	Acetylene Consumption SCFH	Fuel Pressure PSIG	Oxygen Pressure PSIG	Welding Metal Thickness	Brazing Copper Tubing	Replacement Elbow	Replacement Mixer & Nut UM17
Type17-000	30250	1-2	5	5	1/32"	1/8"	Type17E-000	UM17-000
Type17-00	30251	2-3	5	5	3/64"	1/4"	Type17E-00	UM17-000
Type17-0	30252	2-4	5	5	5/64"	1/2"	Type17E-0	UM17-0
Type17-1	30253	3-6	5	5	3/32"	3/4"	Type17E-1	UM17-0
Type17-2	30254	5-10	5	5	1/8"	1"	Type17E-2	UM17-2
Type17-3	30255	8-18	6	7	3/16"	1 1/2"	Type17E-3	UM17-3
Type17-4	30256	10-25	7	10	1/4"	2"	Type17E-4	UM17-4
Type17-5	30257	15-35	8	12	1/4" to 1/2"	3"	Type17E-5	UM17-5
Type17-6	30258	25-45	9	14	1/2" to 3/4"	4"	Type17E-6	UM17-5
Type17-7	30259	30-60	10	16	3/4" to 1 1/4"	6"	Type17E-7	UM17-5

Type17 Weld/Braze Tips
Type17 tips have O-Ring seals, [X26R & X25R] so tighten the tip nut firmly hand tight. **DO NOT OVER-TIGHTEN**



X25R Small O-Ring

X26R Large O-Ring

Part# TXRK Kit includes: (5) X25R & (5) X26R

*NOTE: When acetylene weld/braze tips are used with fuel gases, use one size larger tip and maximum pressures to obtain proper heat. The chart indicates approximate torch oxygen consumption with a neutral flame ratio for various gases: Pressures are approximate for hose length up to 25 ft.; increase for longer lengths about 3 psig per 25 ft. - increase working pressure 2-3 psig for check valves and flashback arrestors. Acetylene delivery pressure should not exceed 15 psig under flow conditions.

1.1 Oxygen to 1 Acetylene
3.5 Oxygen to 1 MAP//Pro™ [Propylene]
4 Oxygen to 1 Propane / Natural gas

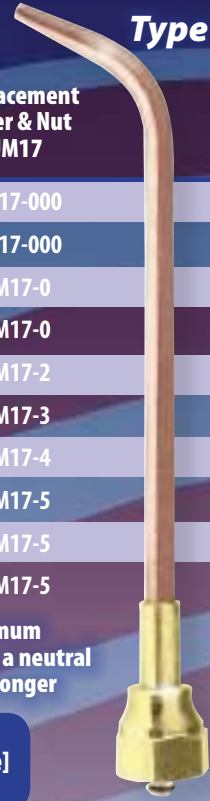

Cutting Tips

This is a metal to metal seating, so be sure to tighten the tip nut wrench tight

Part#	UPC#	Cutting SCFH	Oxygen PSIG	Fuel PSIG	Cutting Tip Guide	Description
5-101-00D	34505	30-35	20-25	5	1/4"	Acetylene 6 preheats for General Purpose Cutting
5-101-0D	34506	40-60	20-30	5	1/2"	
5-101-1D	34507	80-85	30-35	5	3/4" to 1"	
5-101-2D	34508	140-180	35-40	7	1" to 2"	
5-200-0D	34530	40-60	20-30	5	1/2"	Propane 8 preheats for General Purpose Cutting
5-200-1D	34531	80-85	30-35	5	3/4" to 1"	
5-200-2D	34532	140-180	35-40	7	1" to 2"	
5-200M-0D	34555	40-60	20-30	5	1/2"	MAP//Pro™ [Propylene] 8 preheats for General Purpose Cutting
5-200M-1D	34556	80-85	30-35	5	3/4" to 1"	
5-200M-2D	34557	140-180	35-40	7	1" to 2"	
CT100-00D	38010	30-35	20-25	5	1/4"	Acetylene General Purpose Cutting
CT100-0D	38011	40-60	20-25	5	1/2"	
CT100-1D	38012	80-85	30-35	5	3/4" to 1"	
CT100-2D	38013	140-180	35-40	7	1" to 2"	



5-101 Series



5-200 Series



CT100 Series

5-101 & 5-200 Tips fit CA550 Cutting Attachment. CT100 Tips fit CA100 Cutting Attachment.





Welding/Brazing & Heating

and more Tips...

FOR U.S. JOBS
UNIWELD EMPLOYS OVER 300 WORKERS

Rosebuds are your best tip choice for brazing, soldering and heating. They're available 7" and 12" lengths and in several sizes. These tips fit Uniweld 71 and WH550 welding handles.

1 Oxyacetylene

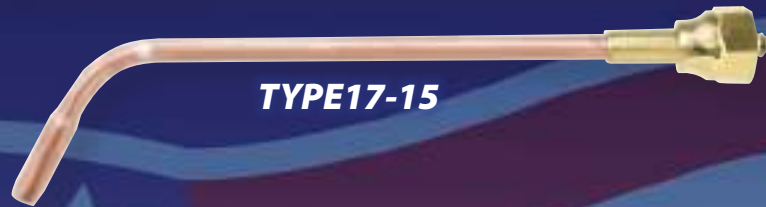

TYPE17-15

Rosebud Heating Tips

Part#	UPC#	Overall Length	Acetylene SCFH	Oxygen PSIG	Acetylene PSIG	Brazing Copper Tubing Guide	Replacement Mixer & Nut
Type17-15	31170	7"	15	12	10	1/8" to 25/8"	UM17-5
*Type17-30	31171	7"	30	15	12	1/2" to 6"	UM17-5
Type28-2	31450	12"	9	8	7	1/8" to 15/8"	UM17-5
Type28-4	31451	12"	14	12	10	1/2" to 3"	UM17-5
*Type28-6	31452	12"	30	15	12	1/2" to 6"	UM17-5
*Type28-8	31453	12"	60	25	15	6" to 8"	UM17-5

*Tips must be used with a 40 cu. ft. or larger cylinder.

Replacement Tip Ends

Part#	UPC#
Type28TE-2	31460
Type28TE-4	31461
Type28TE-6	31462
Type28TE-8	31463

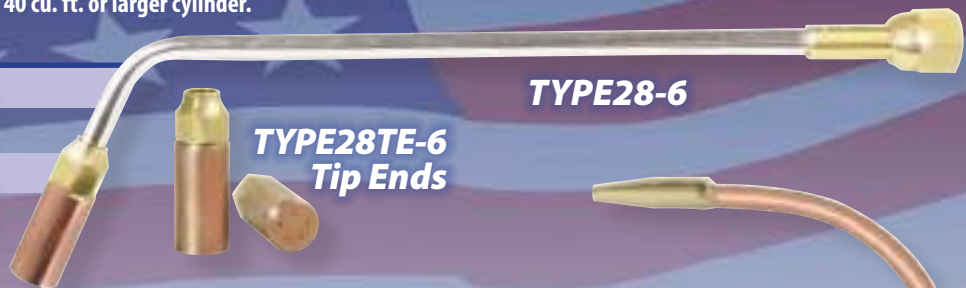

TYPE28-6

TYPE28TE-6 Tip Ends



Flexible tips that you can bend to fit the job...
...even around corners! And then, re-bend 'em for the next job. 10.5" long, including mixer.

TYPE17-9

(2) TYPE17-30 Tip Ends



TYPE13-8VM

Flexible Brazing Tip

Part#	UPC#	Acetylene Consumption SCFH	Oxygen Pressure PSIG	Acetylene Pressure PSIG	Brazing Copper Tubing	Replacement Elbow	Replacement Mixer & Nut
Type17-9	31181	4	5	5	Up to 7/8"	Type17E-9	UM17-5

Twin Rosebud Heating Tip

Type13-8VM	31161	60	25	15	4" - 12"	Type13E-8	UM17-5
------------	-------	----	----	----	----------	-----------	--------

Fits 71 and WH550 Welding Handles.



Uniweld Products, Inc. Fort Lauderdale, FL 33312 U.S.A. Customer Service: 800.323.2111
info@uniweld.com • www.uniweld.com

Tuning Fork™ Tip and Micro 6000™ Tips



Hot Tips

FOR U.S. JOBS
UNIWELD EMPLOYS OVER 300 WORKERS

Heat up all the fittings of a heat pump reversing valve at once for easy removal of the defective valve with the Tuning Fork™ Tip. Remove and install the new valve without altering the original copper tube fittings. The Tuning Fork™ Tip makes it possible to work efficiently in tight spaces and get even heat quickly in tough-to-reach areas.

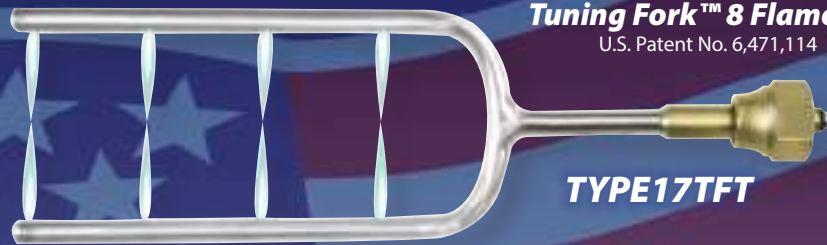

Tuning Fork™ 8 Flame Tip
U.S. Patent No. 6,471,114

TYPE 17TFT

	Part#	UPC#	Acetylene Consumption SCFH	Oxygen Pressure PSIG	Acetylene/Fuel Pressure PSIG	Overall Length	Welding Metal Thickness	Brazing Copper Tubing	Replacement Nut & Mixer
Tuning Fork™ Tip	Type17TFT	31175	5-10	10	7	8"	N/A	7/8"	UM17-5

Tuning Fork™ Tip fits 71 and WH550 welding handles.

Micro 6000™ Tips heat up to 5600°F, providing pinpoint brazing accuracy.

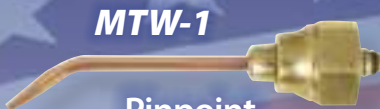

MTW-1

Pinpoint concentrated heat in tight spaces



Stable concentrated flame even in windy conditions

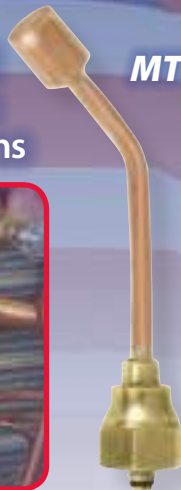

MTR

Adjustable tip ends for maximum control



MTT



	Part#	UPC#	Acetylene Consumption SCFH	Oxygen Pressure PSIG	Acetylene/Fuel Pressure PSIG	Overall Length	Welding Metal Thickness	Brazing Copper Tubing	Replacement Nut & Mixer
Micro 6000™ Tips	MTW-1	30551	2-3	5	5	3"	3/64"	1/2"	N/A
	MTW-2	30552	2-4	5	5	3"	5/64"	1"	N/A
	MTT	30560	4-6	5	5	4"	N/A	1"	N/A
	MTR	30570	4-8	5	5	4"	N/A	1 1/2"	N/A

Micro 6000™ tips fit 71 and WH550 welding handles.



Oxyacetylene, MAP//Pro™ (Propylene), Propane



Cap'n Hook® Tips

U.S. Patent No. 4,191,333

FOR U.S. JOBS
UNIWELD EMPLOYS OVER 300 WORKERS

The patented Uniweld Cap'n Hook® Tip with concentrated heat up to 5600°F. The 40° flame angle flows onto copper tubing and away from sensitive areas, thus minimizing the chances of burning adjacent components. You get 100% wraparound for even heat distribution.

1 Oxyacetylene

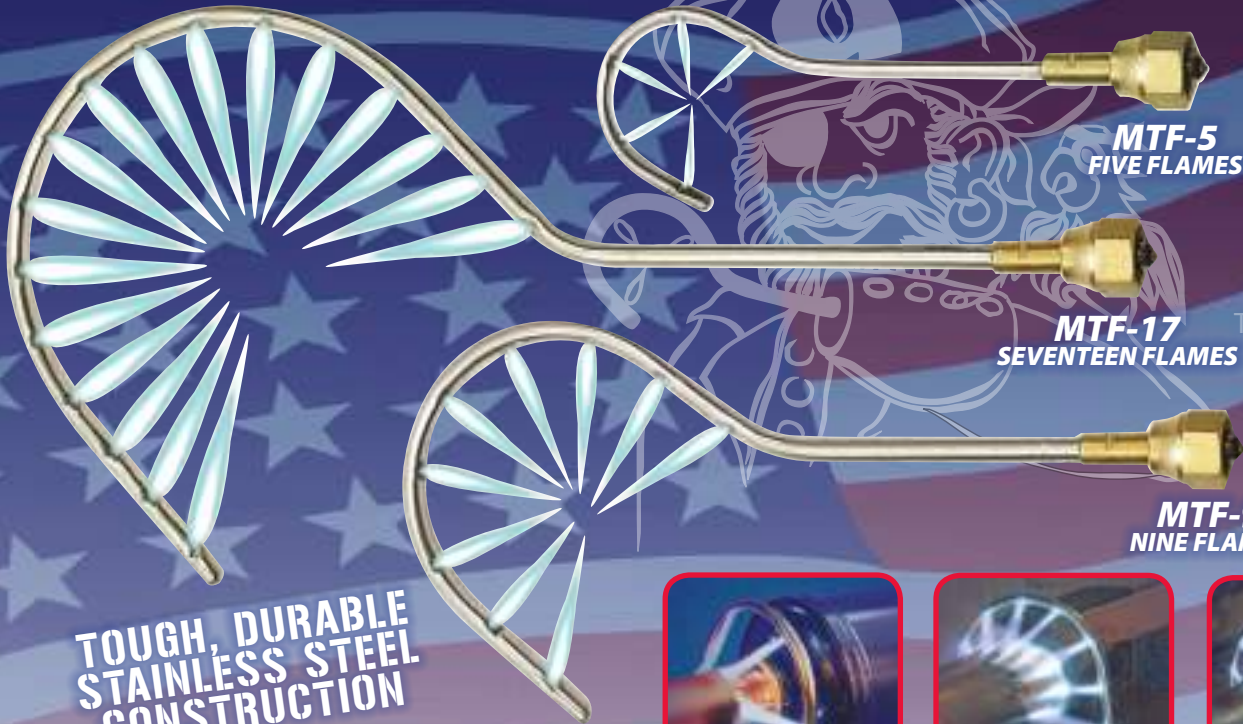

**UP TO 3X
FASTER
BRAZING
SPEED**

**TOUGH, DURABLE
STAINLESS STEEL
CONSTRUCTION**



	Part#	UPC#	Acetylene Consumption SCFH	Oxygen Pressure PSIG	Acetylene Pressure PSIG	Overall Length	Brazing Copper Tubing [up to]
Acetylene	MTF-5	30590	4-6	8	5	5½"	1"
	MTF-9	30591	5-9	10	7	8½"	2"
	MTF-17	30592	8-14	18	12	11"	3"

	Part#	UPC#	MAP//Pro™ [Propylene] /Propane Consumption LBS/HR	Oxygen Pressure PSIG	MAP//Pro™ [Propylene] /Propane Pressure PSIG	Overall Length	Brazing Copper Tubing [Up to]
MAP//Pro™ (Propylene) Propane	MTFM-5	30595	2.6	10	5	5½"	1"
	MTFM-9	30596	3.1	15	7	8½"	2"
	MTFM-17	30597	5.6	20	10	11"	3"

All Cap'n Hook® Tips fit 71, WH550 & WH250 Handles.



Uniweld Products, Inc. Fort Lauderdale, FL 33312 U.S.A. Customer Service: 800.323.2111 info@uniweld.com • www.uniweld.com

Self-Igniting Swirl Combustion Torch Tips



Twister[®] 2

FOR U.S. JOBS
UNIWELD EMPLOYS OVER 300 WORKERS

Twister[®] 2 Tips combine easy start electric ignition with the popular Twister[®] swirl combustion technology to produce a faster igniting and more efficient torch tip. Use with Acetylene.

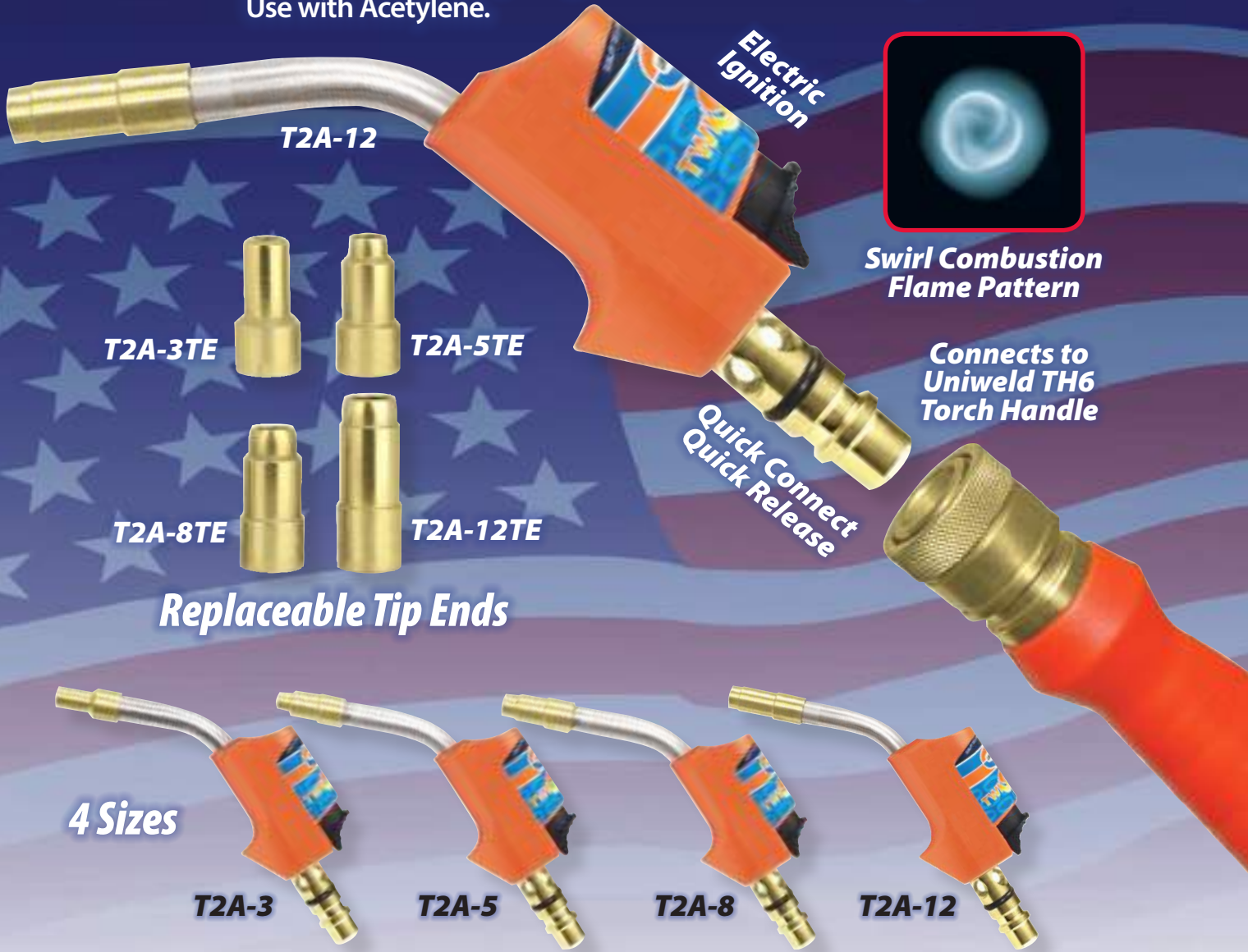

Part#	UPC#	Copper Tubing Capacity		Part#	UPC#	
		Solder	Braze			
Quick Connect	T2A-3	43050	Up to 1"	Tip Ends	T2A-3TE	43060
	T2A-5	43051	3/4" to 1 1/2"		T2A-5TE	43061
	T2A-8	43052	1" to 2"		T2A-8TE	43062
	T2A-12	43053	1 1/4" to 3"		T2A-12TE	43063



Self-Igniting Swirl Combustion Torch Tips



Twister[®] 2 Kits

FOR U.S. JOBS
UNIWELD EMPLOYS OVER 300 WORKERS

Twister[®] 2 self-igniting Torch Kits feature swirl combustion technology that produces a high energy efficient flame. The flame remains stable, even in windy conditions. The self-igniting tip "quick connects" to the ergonomically designed handle.



KT2A5MCT

512 Carrying Stand
U.S. Patent No. 4,294,448

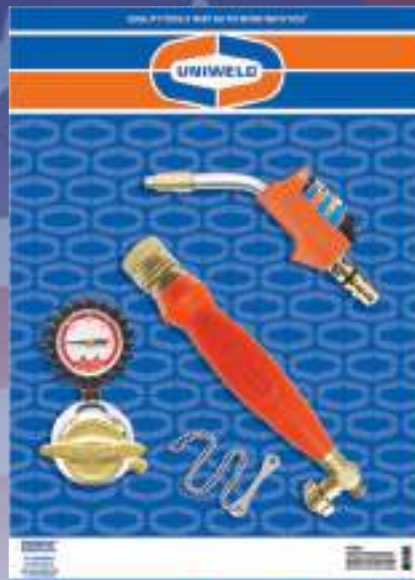

KT2A5

GAUGES WITH PROTECTIVE RUBBER BOOTS



KT2A5T

2 Air/Acetylene

	Part#	UPC#	Regulator	Handle	Tips	Carrying Stands	Tanks*
Quick Connect	KT2A5	89650	RB Acetylene Regulator	TH6	T2A-5 Twister [®] Tip	w/o	w/o
	KT2A5T	89651	RB Acetylene Regulator	Quick Connect Handle with Rear Control Valve	T2A-5 Twister [®] Tip	502	"B" Acetylene Tank
	KT2A5MC	89652	RMC Acetylene Regulator		T2A-5 Twister [®] Tip	w/o	w/o
	KT2A5MCT	89653	RMC Acetylene Regulator		T2A-5 Twister [®] Tip	512	"MC" Acetylene Tank

Regulators fitted with protective rubber gauge boots. Kits include H12 [12.5 ft.] Acetylene Hose, W05 Tank Key w/chain.* Tanks shipped empty.



Uniweld Products, Inc. Fort Lauderdale, FL 33312 U.S.A. Customer Service: 800.323.2111
info@uniweld.com • www.uniweld.com

Swirl Combustion Torch Tips



Twister® Tips

FOR U.S. JOBS
UNIWELD EMPLOYS OVER 300 WORKERS

The popular Air/Fuel Twister® Tips let you work with a stable, high energy efficient flame, even in windy conditions. Twister® helical blade technology maximizes the BTU's and speeds up the heat transfer.

STAINLESS
STEEL FLAME
TUBE



TARGET HEAT AREA
THE MOST EFFICIENT AREA
FOR HEAT TRANSFER.

Quick Connect Twister® Tips
Fit Uniweld's TH6 Quick Connect
Handles With Rear Control Valve





2 Air/Acetylene

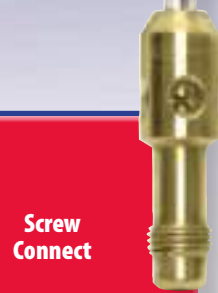

All sizes also
available as
Screw Connect

A-S3



	Part#	UPC#	Copper Tubing Capacity Solder	 Swirl Flame Pattern	Copper Tubing Capacity Brazed	UPC#	Part#
	Quick Connect	A-3	43020		Up to 1"	Up to 1/2"	43025
A-5		43021	3/4" to 1 1/2"	1/4" to 3/4"	43026	AS-5	
A-8		43022	1" to 2"	1/2" to 1"	43027	AS-8	
A-11		43023	1 1/4" to 3"	7/8" to 1 5/8"	43028	AS-11	
A-14		43024	2" to 3 1/2"	1" to 2"	43029	AS-14	
A-32		43040	4" to 6"	1 1/2" to 4"	43041	AS-32	
							Screw Connect



Quick Connect and Screw Connect



Twister® Kits

FOR U.S. JOBS
UNIWELD EMPLOYS OVER 300 WORKERS



89602



89605

GAUGES WITH PROTECTIVE RUBBER BOOTS



89600

2 Air/Acetylene

	Part#	Regulator	Handle	Tips	Carrying Stands	Tanks*
Quick Connect	89600	RB Acetylene Regulator	TH6 Quick Connect Handle Rear Control Valve	A-3, A-11 Twister® Tips	w/o	w/o
	89602	RB Acetylene Regulator		A-3, A-11 Twister® Tips	502	"B" Acetylene Tank
	89603	RMC Acetylene Regulator		A-3, A-11 Twister® Tips	w/o	w/o
	89605	RMC Acetylene Regulator		A-3, A-11 Twister® Tips	512	"MC" Acetylene Tank
	89620	RB Acetylene Regulator		A-5 Twister® Tip	w/o	w/o
	89621	RB Acetylene Regulator		A-5 Twister® Tip	502	"B" Acetylene Tank
	89622	RMC Acetylene Regulator		A-5 Twister® Tip	w/o	w/o
	89623	RMC Acetylene Regulator		A-5 Twister® Tip	512	"MC" Acetylene Tank
	89628	RB Acetylene Regulator		A-5, A-14 Twister® Tips	w/o	w/o
89629	RB Acetylene Regulator	A-8 Twister® Tip	w/o	w/o		
Screw Connect	89608	RB Acetylene Regulator	TH3 Screw Connect Handle Rear Control Valve	AS-3, AS-11 Twister® Tips	w/o	w/o
	89609	RB Acetylene Regulator		AS-3, AS-11 Twister® Tips	502	"B" Acetylene Tank
	89610	RMC Acetylene Regulator		AS-3, AS-11 Twister® Tips	w/o	w/o
	89611	RMC Acetylene Regulator		AS-3, AS-11 Twister® Tips	512	"MC" Acetylene Tank
	89624	RB Acetylene Regulator		AS-5 Twister® Tip	w/o	w/o
	89625	RB Acetylene Regulator		AS-5 Twister® Tip	502	"B" Acetylene Tank
	89626	RMC Acetylene Regulator		AS-5 Twister® Tip	w/o	w/o
	89627	RMC Acetylene Regulator		AS-5 Twister® Tip	512	"MC" Acetylene Tank

Regulators fitted with protective rubber gauge boots. Kits include H12 [12.5 ft.] Acetylene Hose, W05 Tank Key w/chain. *Tanks shipped Empty.



Uniweld Products, Inc. Fort Lauderdale, FL 33312 U.S.A. Customer Service: 800.323.2111
info@uniweld.com • www.uniweld.com

23

Quick Connect and Screw Connect



Thruster® Kits

FOR U.S. JOBS
UNIWELD EMPLOYS OVER 300 WORKERS

The Air/Acetylene Thruster® Kit comes with adjustable flame tips and a fuel conserving Thruster® handle. Excellent for plumbing or repair work in very tight work areas. Select either "quick connect" or "screw connect" tips and either "B" tank or "MC" tank regulators.

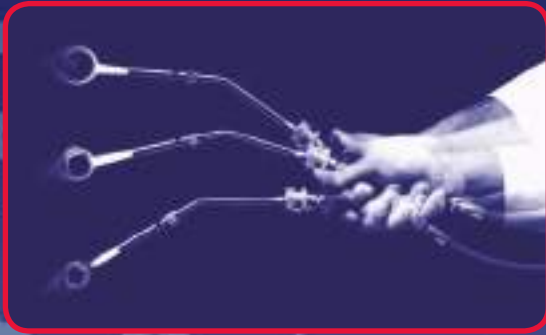

KTAQ23 Quick Connect Kit

2 Air/Acetylene

	Part#	UPC#	Regulator	Tips	Handle
Quick Connect	KTAQ23	89007	RB Acetylene Regulator	ATQ2, ATQ3 Thruster® Tips	TH7 Quick Connect Handle with Fuel-Conserving Pilot Valve
	KTAQ23MC	89008	RMC Acetylene Regulator	ATQ2, ATQ3 Thruster® Tips	
	KTAQ3	89005	RB Acetylene Regulator	ATQ3 Thruster® Tip	
	KTAQ3MC	89006	RMC Acetylene Regulator	ATQ3 Thruster® Tip	
	KTAQ34	89009	RB Acetylene Regulator	ATQ3, ATQ4+ Thruster® Tips	
Screw Connect	KTA23	89002	RB Acetylene Regulator	AT2, AT3 Thruster® Tips	TH5 Screw Connect Handle with Fuel-Conserving Pilot Valve
	KTA23MC	89003	RMC Acetylene Regulator	AT2, AT3 Thruster® Tips	
	KTA3	89000	RB Acetylene Regulator	AT3 Thruster® Tip	
	KTA3MC	89001	RMC Acetylene Regulator	AT3 Thruster® Tip	
	KTA34	89004	RB Acetylene Regulator	AT3, AT4+ Thruster® Tips	

+ATQ4 and AT4 tips must be used with a 40 cu. ft. or larger cylinder and regulator delivery pressure set at 15 PSIG. Kits include H12 [12.5 ft.] Acetylene Hose, W05 Tank Key w/chain. Regulators fitted with protective rubber gauge boots.

	Part#	UPC#	Copper Tubing Capacity	
			Solder	Braze
Quick Connect	ATQ2	43135	1/8" to 1"	1/8" to 7/8"
	ATQ3	43136	5/8" to 3"	3/8" to 2 1/8"
	ATQ4+	43137	1 1/8" to 4"	7/8" to 3"
Screw Connect	AT2	43130	1/8" to 1"	1/8" to 7/8"
	AT3	43131	5/8" to 3"	3/8" to 2 1/8"
	AT4+	43132	1 1/8" to 4"	7/8" to 3"

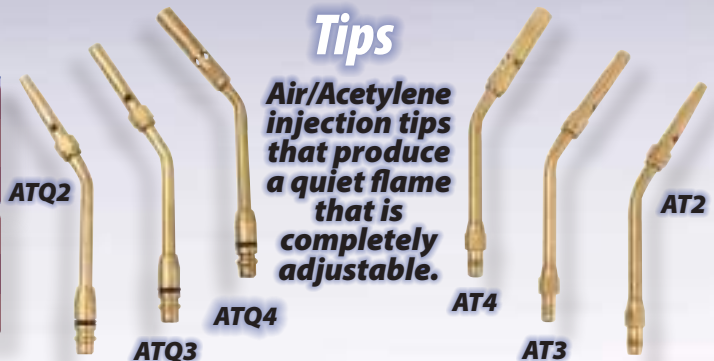



Quick Connect and Screw Connect Soft Flame Kits/Tips

The Air/Acetylene Soft Flame has always been the "Old Reliable" flametool for plumbers, producing a precise 2700°F target heat. An excellent tool for soldering copper tubing.

FOR U.S. JOBS
UNIWELD EMPLOYS OVER 300 WORKERS

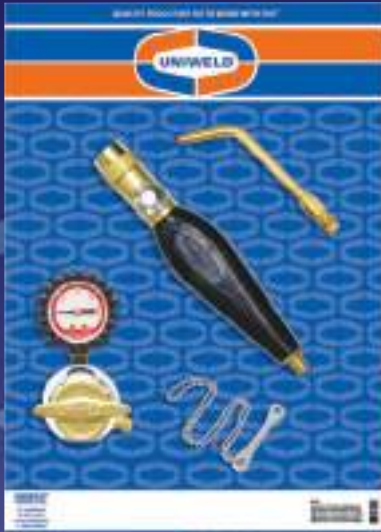

K40

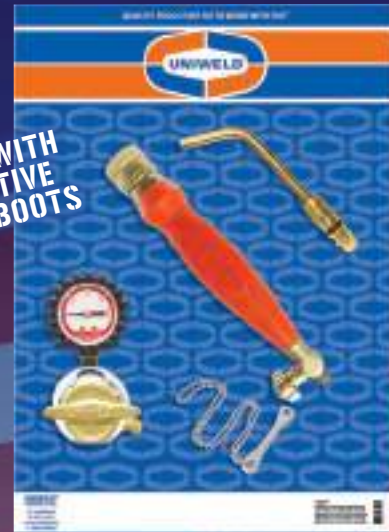

KQ37

GAUGES WITH PROTECTIVE RUBBER BOOTS

Kits

	Part#	UPC#	Regulator	Tips	Handle
Screw Connect	K37	89100	RB Acetylene Regulator	S23 Soft Flame Tip	TH3 Rear Control Valve
	K38	89101	RMC Acetylene Regulator	S23 Soft Flame Tip	TH3 Rear Control Valve
	K40	89102	RMC Acetylene Regulator	S23 Soft Flame Tip	TH9 Front Control Valve
	K41	89103	RB Acetylene Regulator	S23 Soft Flame Tip	TH9 Front Control Valve
Quick Connect	KQ37	89104	RB Acetylene Regulator	ASQ23 Soft Flame Tip	TH6 Rear Control Valve
	KQ38	89105	RMC Acetylene Regulator	ASQ23 Soft Flame Tip	TH6 Rear Control Valve

Kits Include H12 [12.5 ft.] Acetylene Hose, W05 Tank Key w/chain. Regulators fitted with protective rubber gauge boots.

2 Air/Acetylene

Tips

Part#	UPC#	Copper Tubing Capacity Solder	Copper Tubing Capacity Braze	UPC#	Part#
S21	43141	1/16" to 1/8"	Up to 1/16"	43151	ASQ21
S22	43142	1/8" to 3/8"	Up to 1/8"	43152	ASQ22
S23	43143	3/16" to 1/2"	Up to 3/8"	43153	ASQ23
S24	43144	1/2" to 1"	Up to 1/2"	43154	ASQ24
S25	43145	3/4" to 1 1/2"	1/2" to 3/4"	43155	ASQ25
S26	43146	1" to 4"	3/4" to 1 1/2"	43156	ASQ26
S27	43147	1/8" to 3/8"	Up to 1/8"	43157	ASQ27



Uniweld Products, Inc. Fort Lauderdale, FL 33312 U.S.A. Customer Service: 800.323.2111
info@uniweld.com • www.uniweld.com

25



Air/Acetylene Screw Connect

Specialty Tips

FOR U.S. JOBS
UNIWELD EMPLOYS OVER 300 WORKERS

Select from a wide range of Specialty Tips that fit our air/fuel "screw connect" torch handles. This grouping includes our sensitive Halide Leak Detector with probe hose.

2 Air/Acetylene

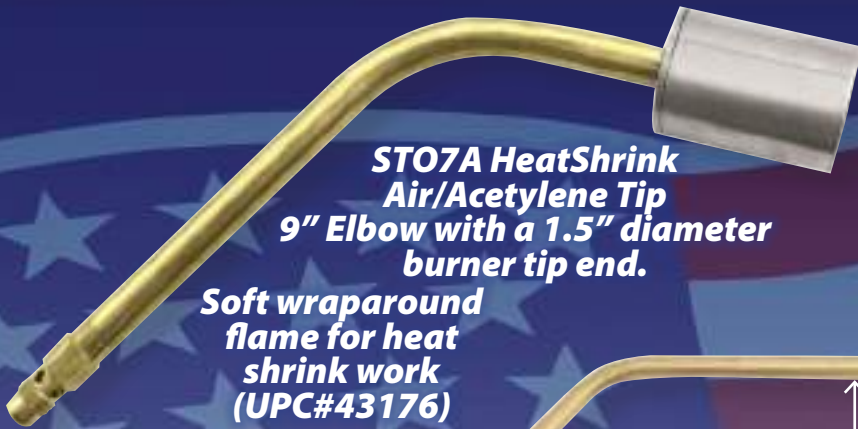

STO7A HeatShrink Air/Acetylene Tip
9" Elbow with a 1.5" diameter burner tip end.

Soft wraparound flame for heat shrink work (UPC#43176)



Halide Leak Detector Tip LD32 with probe hose for Air/Acetylene use (UPC#43200)

HO2-3
3 ft. Probe Hose for LD32 (UPC#43205)

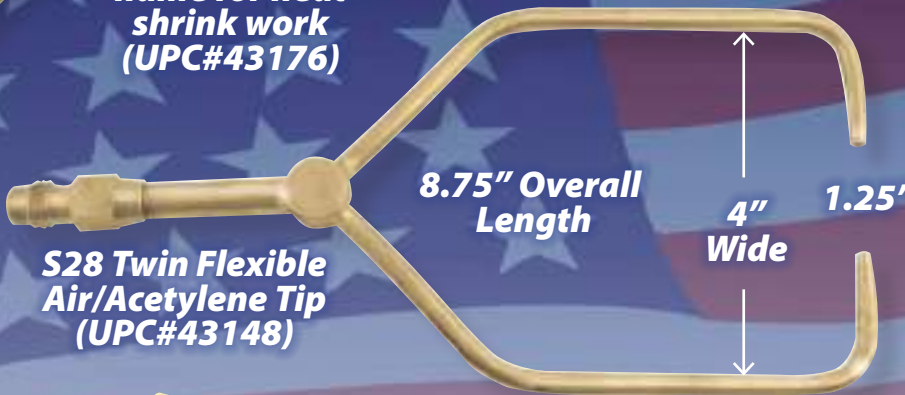

S28 Twin Flexible Air/Acetylene Tip (UPC#43148)

8.75" Overall Length

4" Wide

1.25"



Acetylene Paint Burner PB29
Heavy Duty Forged Brass Burner: 2" wide flame for paint removal and tile cutting (UPC#43190)



Chisel Solder Iron SS37
For Acetylene (UPC#43180)



Chisel Copper Head CH20
For Acetylene (UPC#43182)



Pointed Solder Iron SS38
For Acetylene (UPC#43181)



Pointed Copper Head CH32
For Acetylene (UPC#43183)



A Plumbing and Heating Favorite



LP Twister® Kits

FOR U.S. JOBS
UNIWELD EMPLOYS OVER 300 WORKERS

The popular LP Twister® is a favorite tool among tradesmen in Plumbing and Heating. The Uniweld swirl combustion tips produce a high energy efficient flame for soldering that remains stable in windy conditions. The helical blade inside this tip efficiently premixes the fuel gas and air to deliver maximum combustion and fast heat transfer. Use this tip with Propane or MAP//Pro™ (Propylene) gas.



GAUGES WITH PROTECTIVE RUBBER BOOTS

89606

TARGET HEAT



TARGET HEAT AREA
THE MOST EFFICIENT AREA
FOR HEAT TRANSFER.

Part#/UPC#	89606	89607
Regulator	RLPB L.P. Regulator CGA510	RLPB L.P. Regulator CGA510
Tips	T-4 Quick Connect	TS-4 Screw Connect
Handle	TH6B Rear Control Valve	TH3B Rear Control Valve

Kits include HLP14B [12.5 ft.] L. P. Gas Hose.
Regulators fitted with protective rubber gauge boots.



LP Twister®
Tips



	Part#	UPC#	Copper Tubing Capacity				UPC#	Part#
			Solder	Propane Gas Braze	MAP//Pro™ [Propylene] Gas Solder	MAP//Pro™ [Propylene] Gas Braze		
Quick Connect	T-2	43030	1/8" to 1/4"	1/16" to 1/4"	1/8" to 1/2"	1/8" to 1/4"	43035	Screw Connect
	T-3	43031	1/4" to 1"	1/8" to 1/2"	1/4" to 1 1/2"	1/4" to 1/2"	43036	
	T-4	43032	1/4" to 1 1/2"	1/4" to 3/4"	1/4" to 2 1/2"	1/4" to 1 1/4"	43037	
	T-5	43033	1 1/2" to 2 1/2"	1/2" to 1 1/4"	1" to 4"	1/2" to 2"	43038	



Uniweld Products, Inc. Fort Lauderdale, FL 33312 U.S.A. Customer Service: 800.323.2111
info@uniweld.com • www.uniweld.com

27

3 Air/LP



Quick Connect and Screw Connect LP Thruster® Kits/Tips

Plumbers and Maintenance Repair Tradesmen prefer LP Thruster's proven efficiency and the availability of economical Propane. LP Thruster® tips have a built-in patented screen diffusion flame holder to maximize combustion. The flame is adjustable without tip burnout.

FOR U.S. JOBS
UNIWELD EMPLOYS OVER 300 WORKERS

TARGET HEAT



TARGET HEAT AREA
THE MOST EFFICIENT AREA
FOR HEAT TRANSFER.

Part# UPC#	KLPTQ4 89201	KLPT4 89200
Regulator	RLPB L.P. Regulator CGA510	RLPB L.P. Regulator CGA510
Tips	LPTQ4 Quick Connect	LPT4 Screw Connect
Handle	TH7B Rear Control Valve	TH5B Rear Control Valve

Kits include HLP14B [12.5 ft.] L. P. Gas Hose.
Regulators fitted with protective rubber gauge boots.



GAUGES WITH
PROTECTIVE
RUBBER BOOTS

KLPTQ4

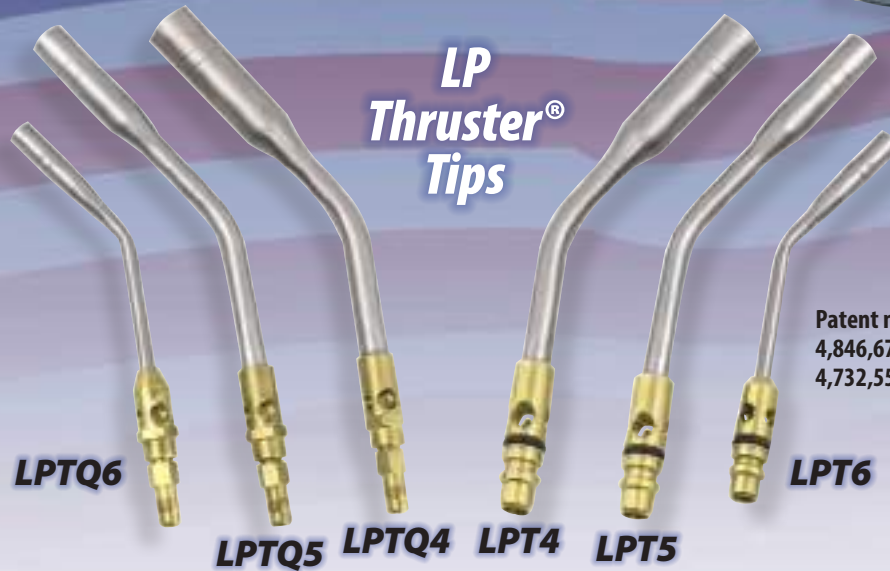

**LP
Thruster®
Tips**

Patent numbers:
4,846,670 and
4,732,559

**3
Air/LP**

Copper Tubing Capacity

	Part#	UPC#	Propane Gas		MAP//Pro™ [Propylene] Gas		UPC#	Part#
			Solder	Braze	Solder	Braze		
Quick Connect	LPTQ4	43165	3/8" to 1"	1/4" to 5/8"	3/8" to 1 1/2"	3/8" to 1"	43160	LPT4
	LPTQ5	43166	5/8" to 2 1/2"	5/8" to 1 3/8"	1" to 2 1/2"	1" to 2"	43161	LPT5
	LPTQ6	43167	7/8" to 3"	7/8" to 2 1/8"	1 1/2" to 4"	1 1/2" to 3"	43162	LPT6
								Screw Connect





Portable Kit with Swivl-it Fitting

LP Thruster® Kits

Lightweight, portable kits featuring "Swivl-it" fittings that eliminate hose kinking and wrist fatigue. Solder up to 1.5" and braze up to 1" copper tubing. Metal carrying stand holds two disposable cylinders.

FOR U.S. JOBS
UNIWELD EMPLOYS OVER 300 WORKERS

TARGET HEAT



TARGET HEAT AREA
THE MOST EFFICIENT AREA
FOR HEAT TRANSFER.



KTSQ2

Part#	UPC#	Regulator	Tips	Handle	Hose	Swivl-it™	Carrying Stand
KTS2	89208	RP3B	LPT4	TH5B	HLP14B	HCC39	512
KTSQ2	89205	RP3B	LPTQ4	TH7B	HLP14B	HCC39	512

Disposable cylinders not included in kits and are sold separately.

**Swivl-it
Kits**

500,000 BTU Weed Burner Scorcher®

A Propane Gas Torch Kit with hundreds of uses, including weed burning, asphalt repair, ice melting, debris burning, fire ant mounds and roofing repairs. Hooks up to a standard 20 lb. Propane (barbeque) tank.

All Steel Handle
10' U.L. Listed Propane Hose with P.O.L. Safety Valve

Part#	UPC#	Description	Hose	Accessories
WB500	00700	Weed Burner 10' w/P.O.L. Safety Valve	Flint Lighter Included	

Sold in units of 6 only.

Scorcher®



Flint Lighter included

All Steel Torch Head



WB500

3 Air/LP



Uniweild Products, Inc. Fort Lauderdale, FL 33312 U.S.A. Customer Service: 800.323.2111
info@uniweild.com • www.uniweild.com



A Concentrated Heat Source

Pencil Point Flame Kits

FOR U.S. JOBS
UNIWELD EMPLOYS OVER 300 WORKERS

The Pencil Point Flame Tip produces a stable, long center cone surrounded by small preheat flames for a concentrated heat source. Use with either Propane or MAP//Pro™ (Propylene) gas without changing the orifice. Solder up to 1.5" and braze up to 7/8" copper tubing.

TARGET HEAT



TARGET HEAT AREA
THE MOST EFFICIENT AREA
FOR HEAT TRANSFER.



K80

Pencil Point

Part#	UPC#	Regulator	Tips	Handle	Hose
K80	89400	RP3A	SM36/SM38	TH3	HLP10SS-3 ft.* w/SHLP
K83	89401	RP3A	SM36/SM38	TH9	HLP11SS-6 ft.* w/SHLP

*Hose Spring included [See Page 33].
Disposable cylinder not included in kits and is sold separately.
Note: these kit's include (2) tips SM36/SM38

Pencil Point Flame Tips

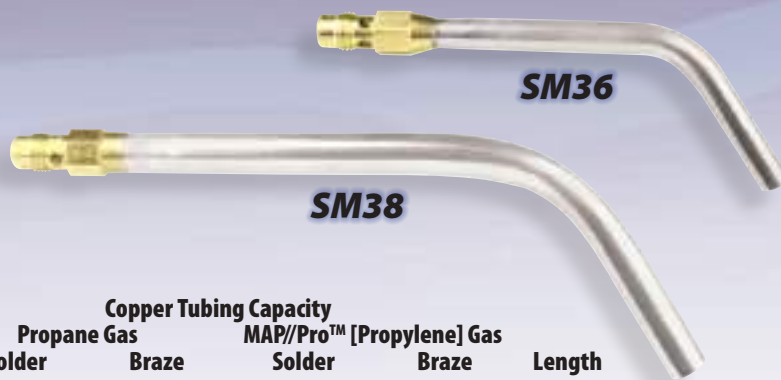

SM36

SM38

Copper Tubing Capacity

Part#	UPC#	Propane Gas		MAP//Pro™ [Propylene] Gas		Length	
		Solder	Braze	Solder	Braze		
Screw Connect	SM36	43170	1/8" to 3/8"	1/16" to 1/4"	1/8" to 1/2"	1/8" to 3/8"	6"
	SM38	43171	1/4" to 1"	1/8" to 1/2"	1/8" to 1 1/2"	1/4" to 7/8"	9"

3 Air/LP

30



Uniweld Products, Inc. Fort Lauderdale, FL 33312 U.S.A. Customer Service: 800.323.2111
info@uniweld.com • www.uniweld.com



A Concentrated Heat Source

Heat Shrink Kits/Tips

FOR U.S. JOBS
UNIWELD EMPLOYS OVER 300 WORKERS

These kits feature specifically designed tips for heat shrink tubing in the telecommunications field. You'll achieve a soft, wraparound flame that spreads the heat quickly and evenly without overheating.

The air and fuel gas mix produces a bright yellow, highly visible flame. Use with either Propane or MAP//Pro™ (Propylene) gas without having to change the orifice.



KCA110

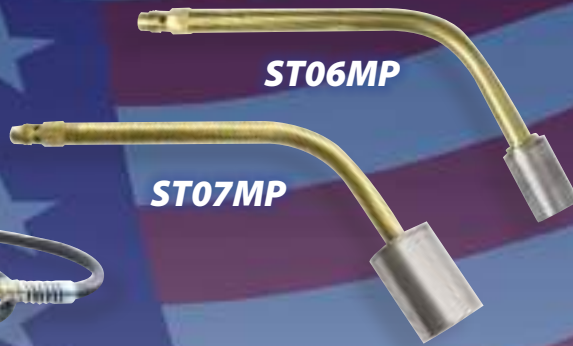

ST06MP

ST07MP

	Part#	UPC#	Regulator	Tips	Handle	*Hose	Size
Heat Shrink Kits	KCA110	89300	RP3A	ST06MP	TH9	HLP11SS	1" O.D. Flame Shield
	KCA111	89301	RP3A	ST07MP	TH9	HLP11SS	1½" O.D. Flame Shield

*6 ft. hose with SHLP Hose Spring [see page 35]. Disposable cylinder is not included in kits and is sold separately.

	Part#	UPC#	Description
Heat Shrink Tips Screw Connect	ST06MP	43175	Propane / MAP//Pro™ [Propylene] 9" elbow with a 1" O.D. Flame Shield
	ST07MP	43177	Propane / MAP//Pro™ [Propylene] 9" elbow with a 1½" O.D. Flame Shield
	ST07RSM	43178	Propane / MAP//Pro™ [Propylene] 7" elbow with a 1½" O.D. Flame Shield
	ST07A	43176	Acetylene 9" elbow with a 1½" O.D. Flame Shield

Unitorch® Regulators

The safest available for disposable cylinders. A piston inside the regulator eliminates leakage problems. Operates in an upside down position (time, temperature and contents dependent).



RP3A

RP3B

RP3E

	Part#	UPC#	Description
Unitorch® Regulators	RP3A	43000	Unitorch® Regulator with "A" outlet fitting
	RP3B	43001	Unitorch® Regulator with "B" outlet fitting
	RP3E	43002	Unitorch® Regulator with 360° swivel elbow for use with UT2, UT3, UT4, UT5 and UT6 replacement tips



Uniweild Products, Inc. Fort Lauderdale, FL 33312 U.S.A. Customer Service: 800.323.2111
info@uniweild.com • www.uniweild.com

31

3 Air/LP

Thruster®, Twister®, Double & Triple Twister®



Hand Torches

FOR U.S. JOBS
UNIWELD EMPLOYS OVER 300 WORKERS

Uniweld Hand Torches are the right choice for small jobs in tight areas with limited access. These lightweight, portable flametools can be operated with Propane or MAP//Pro™ (Propylene). Hand torches are shipped on display cards or in clamshell packaging.

PCV25 Pencil Flame Hand Torch

Adjustable pencil point flame for soldering copper tubing and thawing frozen pipes.



RP3T5 Hand Torch

LP Twister® Tip utilizes swirl combustion technology to produce a high energy efficient flame. The flame remains stable in windy conditions. RP3E Unitorch Regulator with swivel elbow and UT5 Twister® Tip



DOUBLE
THE POWER
DOUBLE THE
HEAT



TRIPLE
THE POWER
TRIPLE THE
HEAT



RP3T2 Hand Torch UT2 Double Twister® Tip



RP3T3 Hand Torch UT3 Triple Twister® Tip



3 Air/LP

Tubing Capacity

Part#	UPC#	Propane		MAP//Pro™ [Propylene]		Replacement Tip
		Solder	Braze	Solder	Braze	
PCV25	43210	Up to 7/8"	Up to 3/8"	Up to 1"	Up to 5/8"	N/A
RP3T2	43007	Up to 3 1/2"	Up to 2"	Up to 4"	Up to 3"	UT2
RP3T3	43008	Up to 4"	Up to 2 1/2"	Up to 6"	Up to 4"	UT3
RP3T4*	43004	Up to 3"	Up to 1"	Up to 3 1/2"	Up to 1 3/4"	UT4*
RP3T5	43005	Up to 3"	Up to 1"	Up to 3 1/2"	Up to 1 3/4"	UT5
MKT-4L	89501	Up to 3"	Up to 1"	Up to 3 1/2"	Up to 1 3/4"	UT5

MKT-4L includes RP3T5 Hand Torch with [1] MAP//Pro™ disposable cylinder. Shipped in display box [6 per case].



MKT-4L

* LP Thruster® Tip with screen diffusion flame holder for flame adjustment without tip damage.

Self-igniting Swirl Combustion Tips



Hand Torches

FOR U.S. JOBS
WELD EMPLOYERS OVER 300 WORKERS

Uniweld Self-igniting Hand Torches eliminate the need for a flint lighter. Lightweight and portable, these flame tools can be operated with Propane or MAP//Pro™ (Propylene).



Tip Swivels 360°

Operates in any position, even upside down



Pull down on bullet casing to activate spark igniter



TARGET HEAT AREA THE MOST EFFICIENT AREA FOR HEAT TRANSFER.

Tip Swivels 360°

HT44 Twister® 2 Hand Torch

360° Swivel Tip
Operates in any position, even upside down

HT44TE Twister® swirl combustion Tip End

RP3T6 Silver Bullet® Hand Torch

UT6 LP Twister® Silver Bullet® Tip Stainless Steel and Aluminum construction



Trigger Lock with Instant Safety Release
Full-size comfort grip

Tubing Capacity

Hand Torches	Part#	UPC#	Propane		MAP//Pro™ [Propylene]		Replacement Tip
			Solder	Braze	Solder	Braze	
	RP3T6	43006	Up to 3"	Up to 1"	Up to 3½"	Up to 1¾"	UT6
	HT44	43216	Up to 3"	Up to 1"	Up to 4"	Up to 1¼"	HT44TE

Disposable cylinders not included and are sold separately.



Uniweld Products, Inc. Fort Lauderdale, FL 33312 U.S.A. Customer Service: 800.323.2111
info@uniweld.com • www.uniweld.com

33

3 Air/LP



Ergonomic, durable Torch Handles

FOR U.S. JOBS
UNI WELD EMPLOYS OVER 300 WORKERS

Rugged, ergonomically designed air/fuel torch handles provide you with better grip, balance and comfort. Handle options include screw connect or quick connect, "A" or "B" inlet connections and front or rear control valves.

QUICK CONNECT HANDLES



TH6

TUA Screw Connect



Screw Connect Tip to Quick Connect Air/Fuel Handle Adaptor
UPC#43120



TH7



TH8

SCREW CONNECT HANDLES

UTA Quick Connect



Quick Connect Tip to Screw Connect Air/Fuel Handle Adaptor
UPC#43121



TH3



TH5



TH9

Air/Acetylene Gas "A"
(3/8" -24) L.H. Inlet Connection

Air/LP Gas "B"
(9/16" -18) L.H. Inlet Connection

	Part#	UPC#	
Screw Connect	TH3	43100	Rear Valve
	TH5	43105	Front Pilot Valve
	TH9	43113	Front Valve
Quick Connect	TH6	43107	Rear Valve
	TH7	43109	Front Pilot Valve
	TH8	43111	Front Valve

	Part#	UPC#	
Screw Connect	TH3B	43101	Rear Valve
	TH5B	43106	Front Pilot Valve
	TH9B	43114	Front Valve
Quick Connect	TH6B	43108	Rear Valve
	TH7B	43110	Front Pilot Valve
	TH8B	43112	Front Valve

4 Parts & Accessories



"A", "B" and "AB" Connections



Hoses

FOR U.S. JOBS
UNIWELD EMPLOYS OVER 300 WORKERS

Uniweld flexible Oxyfuel Hoses are color coded, have 8-sided crimp ferrules and are capable of withstanding high working pressures for reliability and long work life.

HLP14B



H32A

Hose Spring

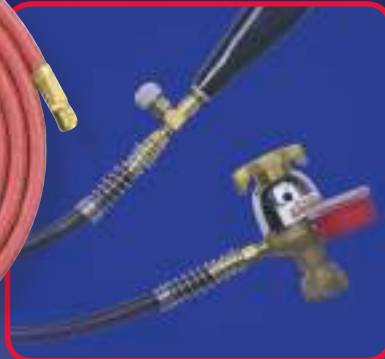

H12

Hose Spring (Part#SHLP) may be added to Acetylene or LP gas hoses by adding an (S) for one spring or (SS) for two springs (one @ each end) to the hose Part#. Example: H12S, H12SS/HLP14BS, HLP14BSS

4 Parts & Accessories

	Oxyacetylene Twin Hose 3/16" I.D., Max. W.P. 200 psi			
	Part#	UPC#	Length	Connection
Oxyacet. Twin Hose	H32A	43510	12.5 ft.	"A"
	H32B	43512	12.5 ft.	"B"
	H32AB	43511	12.5 ft.	"AB**"
	H33A	43513	25 ft.	"A"
	H33B	43515	25 ft.	"B"
	H33AB	43514	25 ft.	"AB**"
	H34A	43516	50 ft.	"A"
	H34B	43517	50 ft.	"B"

**"AB" - "A" fitted one end, "B" fitted opposite end

	LP Gas Single Hose 3/16" I.D., Max. W.P. 125 psi			
	Part#	UPC#	Length	Connection
LP Gas Single Hose	HLP10	43530	3 ft.	"A"
	HLP10B	43531	3 ft.	"B"
	HLP11	43533	6 ft.	"A"
	HLP11B	43534	6 ft.	"B"
	HLP13	43537	25 ft.	"A"
	HLP13B	43538	25 ft.	"B"
	HLP14	43541	12.5 ft.	"A"
	HLP14B	43542	12.5 ft.	"B"

	Acetylene Single Hose 3/16" I.D., Max. W.P. 200 psi			
	Part#	UPC#	Length	Connection
Acetylene Single Hose	H11	43500	6 ft.	"A"
	H11B	43501	6 ft.	"B"
	H12	43502	12.5 ft.	"A"
	H12B	43503	12.5 ft.	"B"
	H13	43504	25 ft.	"A"
	H13B	43505	25 ft.	"B"

	Oxy/LP Gas Grade "T" Twin Hose 3/16" I.D., Max. W.P. 200 psi			
	Part#	UPC#	Length	Connection
Oxy/LP Grade "T" Twin Hose	H32AT	43560	12.5 ft.	"A"
	H32BT	43561	12.5 ft.	"B"
	H32ABT	43562	12.5 ft.	"AB**"

**"AB" - "A" fitted one end, "B" fitted opposite end



H32AT

Reference Information: "A" = 3/8" - 24 "B" = 9/16" - 18



Uniweld Products, Inc. Fort Lauderdale, FL 33312 U.S.A. Customer Service: 800.323.2111
info@uniweld.com • www.uniweld.com

35



"Patriot" Series Regulators

FOR U.S. JOBS
UNIWELD EMPLOYS OVER 300 WORKERS

Patriot Series Regulators feature protective rubber gauge boots, rear inlet service and various CGA cylinder connections. Specially compounded diaphragm and seat material provide accuracy and reliability. Listed.

4 Parts & Accessories

	Part#	UPC#	CGA Inlet	Outlet Connection	1 1/2" Delivery/Contents	Delivery PSI
Oxygen	RO	12000	540	"A" RH	[G49D] 100/4000 [G56D]	2-60
	ROB	12001	540	"B" RH	[G49D] 100/4000 [G56D]	2-60
Acetylene	RMC	12006	200	"A" LH	Contents [G19D]	2-15
	RMC2	12007	200	"A" LH	[G15D] 30/Contents [G19D]	2-15
	RB	12010	520	"A" LH	Contents [G19D]	2-15
	RB2	12011	520	"A" LH	[G15D] 30/Contents [G19D]	2-15
LP Fuel Gas	RLP	12014	510	"A" LH	60 Delivery [G83D]	2-40
	RLPB	12015	510	"B" LH	60 Delivery [G83D]	2-40



RMC2

GAUGES WITH PROTECTIVE RUBBER BOOTS

FV600 Oxy/Fuel Adapter

Fuel Valve Adapter to connect a Uniweld Acetylene MC Regulator (CGA200) to a disposable fuel cylinder (CGA600). All Uniweld Acetylene regulator diaphragms and seals are compatible for use with either Propylene (MAP//Pro™) or Propane

fuel gas. **WARNING!**: Fuel compatibility with other manufacturer's Acetylene regulators must be determined prior to use. If not compatible, another option would be to replace the Acetylene regulator with an RP3A regulator.



FV600

The Uniweld 71 welding handle & Type17 Weld/Braze tips will work properly using either of the fuel gases combined with Oxygen. The CA550 cutting attachment will also work with either fuel gas. However, the cutting tip is fuel specific and must be changed (see page 16). Also, the Cap'n Hook® tips are fuel specific. (see page 19). It is recommended to use grade "T" hose (H32AT) with Propylene (MAP//Pro™) or Propane fuel gas. If using grade "R" hose (H32A) with Propylene (MAP//Pro™) or Propane fuel gas, it must never be used in extremely cold temperatures below -10 °F. This may cause the fuel gas to liquefy and act as a solvent that will attack the internal hose material. Always bleed off the remaining fuel gas in the hose after each use.

There will be a noticeable performance and temperature difference when using Propylene (MAP//Pro™) versus Acetylene and an increase in oxygen consumption.

Fuel	Temp °F	Ratio Oxy/Fuel
Acetylene	5589 °F	1-1
MAP//Pro™	5193 °F	3.5-1
Propane	4579 °F	4-1

It is highly recommended to use a Type17-3 or larger tip for brazing 3/8" and 7/8" copper line sets.





"Mastar® and Centurion®" Series Regulators

FOR U.S. JOBS
UNIWELD EMPLOYS OVER 300 WORKERS



Centurion®

RO100

The economical, lightweight Centurion® Series Regulators feature rugged brass bodies. 1.5" gauges and protective rubber gauge boots.

GAUGES WITH PROTECTIVE RUBBER BOOTS



Mastar®

RSMC2

Uniweild's top-of-the-line, single stage Mastar® Series Regulators have two 1.5" gauges, a 3" pressure adjusting "T" handle and protective rubber gauge boots.  Listed

		Part#	UPC#	CGA Inlet	Outlet Connection	Delivery 1 1/2" Gauges/Contents	Delivery PSI
Centurion®	Oxygen	R0100	14100	540	"A" RH	[G49D] 100/4000 [G56D]	2-60
	Acetylene	RMC100	14102	200	"A" LH	[G15D] 30/Contents [G19D]	2-15
Mastar®	Oxygen	RSO	12100	540	"A" RH	[G49D] 100/4000 [G56D]	2-60
		RSOB	12101	540	"B" RH	[G49D] 100/4000 [G56D]	2-60
		12106	12106	540	"A" RH	[psi/kg] [G85-1D] 100/4000 [G82-1D]	2-60
	Acetylene	RSMC2	12102	200	"A" LH	[G15D] 30/Contents [G19D]	2-15
		RSMC2B	12103	200	"B" LH	[G15D] 30/Contents [G19D]	2-15
		RSB2	12104	520	"A" LH	[G15D] 30/Contents [G19D]	2-15
		RSB2B	12105	520	"B" LH	[G15D] 30/Contents [G19D]	2-15
12107	12107	520	"A" LH	[psi/kg] [G79-1D] 30/400 [G73-1D]	2-15		

All regulators with "A" [3/8" - 24] outlet fittings are available with "B" [9/16" - 18] outlet fittings. To order, add "B" to the Part Number. Pressure relief devices are not designed to protect downstream equipment.

Replacement Gauges

1 1/2" Gauges [1/8" NPT] with Protective Rubber Boots



G49D

Oxygen

G49D 100 psi, Steel Case
G56D 4000 psi, Steel Case

Acetylene

G15D 30 psi, Steel Case, Red Line 15-30 psi
G19D 1/4, 1/2, 3/4, Full [Contents] Steel Case, [400 psi Max]



G19D

GB155 Protective Rubber Boot for all 1 1/2" Gauges [Pkg. of 2]

Gauge Part Numbers without D are individually boxed. Gauge Part Numbers with D denote hanging display packaging [D=pkg]. For complete replacement welding gauge information, refer to page 99.



Uniweild Products, Inc. Fort Lauderdale, FL 33312 U.S.A. Customer Service: 800.323.2111
info@uniweild.com • www.uniweild.com



CGA Valve Connections Cylinders FOR U.S. JOBS

UNIWELD EMPLOYS OVER 300 WORKERS

4 Parts & Accessories

	Part#	Description		CGA200	VALVE	NIPPLE	NUT
"MC" Tank	MC24	Nut	Acetylene	.625" - 20 NGO-R.H.			
	MC52	Nipple		7/16" - 20 UNF, 1 1/8" Long [R]			
	Used on: RMC Approx. 10 cu. ft. cylinder only						
"CA" Tank	8159-4	Nut	Acetylene	.830" - 14 NGO-R.H.			
	11A05	Nipple		7/16" - 20 UNF, 1 5/16" Long [R]			
	8112-3	Nipple		1/4" - 18 NPT, 1 5/16" Long [RUH]			
	Used on: R, RUH, RHG, RHT, RVT, MR						
	8159-3	Nut	Carbon Dioxide	.830" - 14 NGO-R.H.			
	8312	Nipple		1/4" - 18 NPT, 2" Long			
	X09R	O-Ring		[Do not use with Gasket]			
	Used on: CEF, RUH, RHF, RHT, RV, RVT, RHFG, R1300 [CO ₂] Use "O-Ring X09R only for 8312 Nipple, Not Gasket"						
	8959	Nut	Air	.830" - 14 NGO-R.H.			
	1805	Nipple		1/4" - 18 NPT, 2 1/2" Long			
	Used on: RV, RVT, RHT, RUH, R1800 Regulators						
	8859	Nut	Hydrogen	.830" - 14 NGO-L.H.			
	8812-2	Nipple		1/4" - 18 NPT, 2 1/2" Long			
	Used on: RUH, RV, RVT, RHT Regulators						
"POL" Tank	8159-2	Nut	Acetylene and Fuel Gas	.880" - 14 NGO-L.H.			
	1205	Nipple		7/16" - 20 UNF 2 3/16" Long [R]			
	1205-2	Nipple		1/4" - 18 NPT, 2 13/32" Long [MR]			
	8112-2	Nipple		1/4" - 18 NPT, 3 3/16" Long [RV, RUH]			
Used on: R, RUH, RHT, RHG, RV, RVT, MR Regulators CGA415 [ALC] [Canada only] on request							
"B" Tank	B10	Nut	Acetylene	.899" - 18 NGO-R.H.			
	B51	Nipple		7/16" - 20 UNF 1 1/4" Long [R]			
	RU12-2	Nipple		1/4" - 18 NPT, 2 3/8" Long [MR, RUH]			
Used on: RB, RUH, MR, R Regulators Cylinder: 35-75 cu. ft. only							
	8059-2	Nut	Oxygen Only	.908" - 14 NGO-R.H.			
	1005-3*	Nipple		7/16" - 20 UNF 1 19/32" Long [R]			
	8012-2	Nipple		1/4" - 18 NPT, 2" Long [RV]			
	RU12	Nipple		1/4" - 18 NPT, 2 9/16" Long [RUH]			
Used on: MR, RHG, RHT, RV, RVT, RUH Regulators; For Oxygen Service Only *1005 1/4" - 18NPT[R]							
	8759	Nut	Argon Helium Nitrogen	.960" - 14 NGO-R.H.			
	1205	Nipple		7/16" - 20 UNF 2 3/16" Long [R]			
	1205-2	Nipple		1/4" - 18 NPT, 2 13/32" Long [CEF]			
	8112-2	Nipple		1/4" - 18 NPT, 3 3/16" Long [RHF, RHFG]			
Used on: RUH, RV, RVT, RHF, CEF, RHT, RHFG, R1500 [Ni], RAR, R15NI Regulators Alternative Connections: CGA590 [LH], CGA555 [LH] on Request							

Source: Compressed Gas Assoc., Std. V-1, 1994





Cylinder to Regulator Adaptors FOR U.S. JOBS

UNIWELD EMPLOYS OVER 300 WORKERS

Part# F10X
UPC# 43300
CGA580 to
CGA540



Part# F22X
UPC# 43303
CGA540 to
CGA580



Part# F24X
UPC# 43304
CGA510 "POL"
to CGA300 "CA"



Part# F25
UPC# 43305
CGA200 "MC" 90°
to CGA510 "POL"



Part# F28
UPC# 43306
CGA300 "CA"
to CGA510 "POL"



Part# F31
UPC# 43307
CGA520 "B" to
CGA200 "MC"



Part# F33
UPC# 43309
CGA520 "B" 90°
to CGA510 "POL"



Part# F32
UPC# 43308
CGA510 "POL"
to CGA520 "B"



Part# F34
UPC# 43310
CGA200 "MC" 90°
to CGA520 "B"



Part# F35
UPC# 43311
CGA300 "CA" to
CGA520 "B"



Part# F36
UPC# 43319
CGA320 "CO2"
to CGA580



Part# F37
UPC# 43312
CGA510 "POL" to
CGA200 "MC"



Part# F38
UPC# 43313
CGA300 "CA" to
CGA200 "MC"



Part# F50
UPC# 43315
CGA520 "B" 90°
to CGA520 "B"



Part# F41
UPC# 43314
CGA200 "MC" to
CGA520 "B"



Part# F60
UPC# 43316
CGA410 Fitting to
CGA510 "POL"



Part# F61X
UPC# 43317
CGA520 "B" to
CGA300 "CA"



BRASS HOSE CLAMPS



HOSE NIPPLE



Hose Fittings

HOSE NUT



HOSE SPLICE [Push Type]



Part#	UPC#	HOSE I.D.
HC01	43376	3/16"
HC02	43377	1/4"

Part#	UPC#	Nipple Size	Hose Nut
HN83P	43370	3/16"	"A"
HN87	43371	3/16"	"B"
HN84	43372	1/4"	"B"

Part#	UPC#	Hose Nut	to Nipple Size
HN82A	43348	"A" RH	3/16"
HN83A	43349	"A" LH	3/16"
9059	43350	"B" RH	1/4" or 3/16"
9059-2	43351	"B" LH	1/4" or 3/16"

Part#	UPC#	Hose to Hose
HS53	43373	1/4" to 1/4"
HS54	43374	3/16" to 1/4"
HS55	43375	3/16" to 3/16"

4 Parts & Accessories

"A" to "B"
Outlet Adaptor

Part#	UPC#	Regulator	To Hose
F27L	43320	"A" Conn LH	"B" Hose Nut LH
F27R	43321	"A" Conn RH	"B" Hose Nut RH

"A" to "B"
Outlet Adaptor

Part#	UPC#	Regulator	To Hose
F58L	43325	"A" Conn LH	"B" Hose Nut LH
F58R	43326	"A" Conn RH	"B" Hose Nut RH

"B" to "A"
Outlet Adaptor

Part#	UPC#	Regulator	To Hose
F59L	43327	"B" Conn LH	"A" Hose Nut LH
F59R	43328	"B" Conn RH	"A" Hose Nut RH

Adaptor and Connectors

"A" to "B" Welding Handle Adaptor

Part#	UPC#	Handle to Hose
F29L	43322	"A" Conn LH "B" Hose Nut LH
F29R	43324	"A" Conn RH "B" Hose Nut RH

Hose Coupling

Part#	UPC#	Hose Nut	to Hose Nut
HCC40	43342	"A" LH	"A" LH
HCC46	43343	"A" LH	"B" LH
HCC41	43344	"A" RH	"A" RH
HCC79	43345	"B" LH	"B" LH
HCC47	43346	"A" RH	"B" RH
HCC78	43347	"B" RH	"B" RH

Part# UPC# Inlet to Outlet

"A" Size "Y" Outlet Adaptor

FY11XA	43332	"A" LH	"A" Hose Nut LH
FY10XA	43331	"A" RH	"A" Hose Nut RH

"Y" Connectors w/Valves

FY10XAV	43334	"A" RH	"A" Hose Nut RH
FY11XAV	43335	"A" LH	"A" Hose Nut LH
FY10XV	43336	"B" RH	"B" Hose Nut RH
FY11XV	43337	"B" LH	"B" Hose Nut LH

"B" Size "Y" Connectors

FY11X	43330	"B" LH	"B" Hose Nut LH
FY10X	43329	"B" RH	"B" Hose Nut RH





Disposable and Refillable Cylinders & Tanks

FOR U.S. JOBS
UNIWELD EMPLOYS OVER 300 WORKERS

4 Parts & Accessories



	Part#	UPC#	Approx. Cap. cu. ft.	O.D. Inches	Height w/valves Inches	Weight Lbs.	CGA Connection
Acetylene	MC	40032	10.00	4.00	15.00	8.00	200
	B	40033	40.00	6.00	23.25	25.5	520
Oxygen	R	40034	20.00	5.25	18.5	12.7	540
	R40	40035	40.00	7.00	22.5	32.00	540
Nitrogen	N20	40036	20.00	5.25	18.5	12.7	580
	N40	40037	40.00	7.00	22.5	32.00	580
	N60	40041	60.00	7.00	27.00	39.00	580
*MAP//Pro™	MDC	40030	14.1 oz.	3.00	11.00	2.00	600
*Propane	PDC	40031	14.1 oz.	3.00	11.00	1.75	600

All tanks are shipped empty. • *Sold in case lot quantity only - 12 per case. - Disposable Propane and MAP//Pro™ cylinders are shipped full and meet DOT 39NRC specifications. MAP//Pro™ is a trademark of Worthington Industries.



TGCMC

Protect yourself against shortages by checking the cylinder contents with a Test Gauge.

Reading of Contents:

- Oxygen Pressure 1800-2200 PSI
- Acetylene Pressure 1/4, 1/2, 3/4 or FULL
- Nitrogen Pressure 1800-2200 PSI



Part#	UPC#	Description
TGCB	41250	"B" Tank Test Gauge
TGCMC	41251	"MC" Tank Test Gauge
TGCN	41252	Nitrogen Tank Test Gauge
TGCO	41253	Oxygen Tank Test Gauge

40



Uniweld Products, Inc. Fort Lauderdale, FL 33312 U.S.A. Customer Service: 800.323.2111
info@uniweld.com • www.uniweld.com



Plastic and Metal

Carrying Stands

FOR U.S. JOBS
UNIWELD EMPLOYS OVER 300 WORKERS

The rugged Uniweld line of Carrying Stands and Cylinder Trucks provides convenience, portability and organization. All blue enameled steel models feature fitted hand grips and hose holders. The center-balanced blue plastic tote has storage space for cylinders, hoses and accessories.

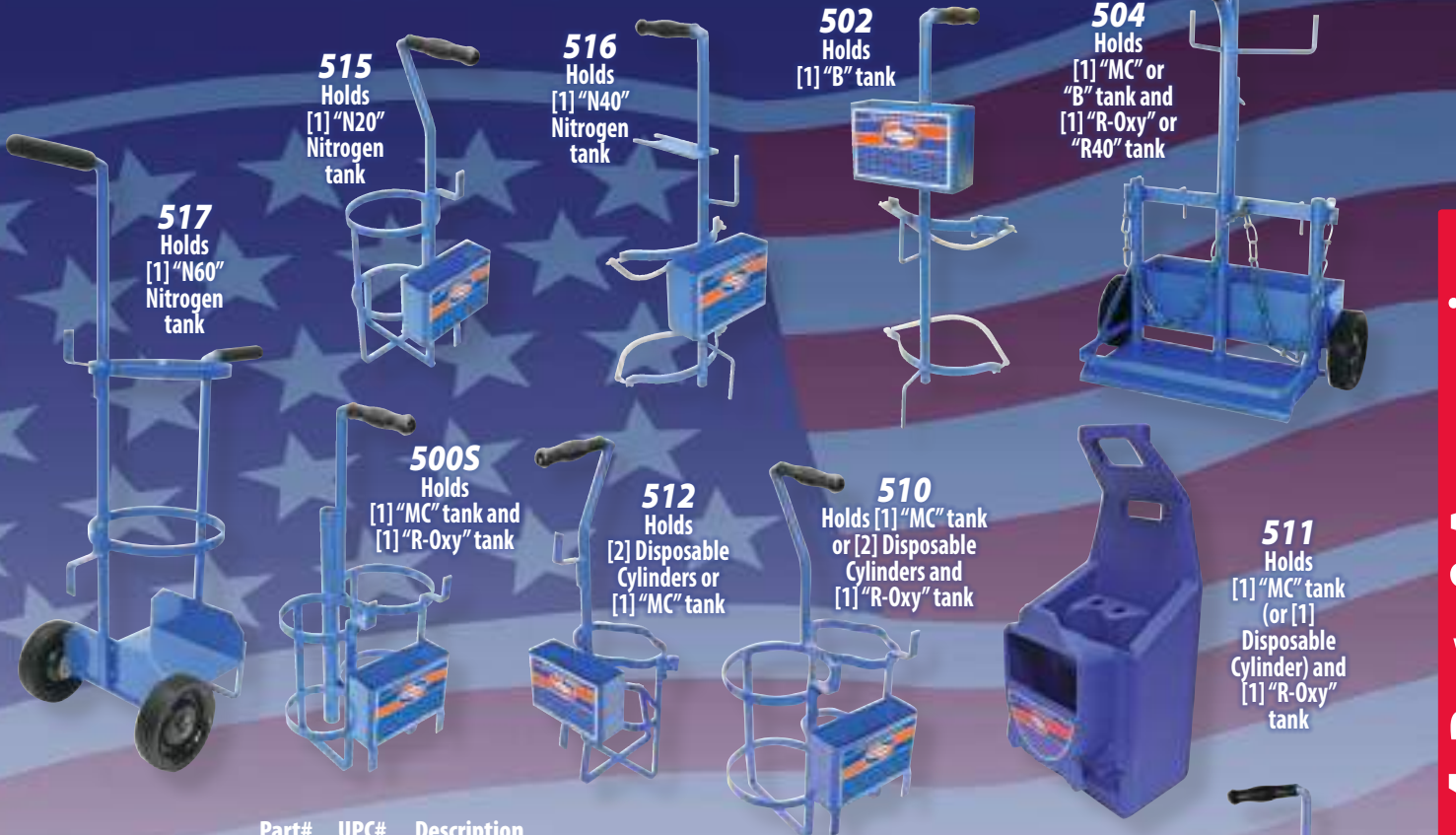

4 Parts & Accessories

Part#	UPC#	Description
500S	30001	Carrying stand for [1] "MC" tank & [1] "R-Oxy" tank w/utility tray & brazing rod holder
502	30003	Carrying stand for [1] "B" tank w/utility tray & Air/Fuel handle holder
503	30004	Carrying stand with wheels for [1] "B" tank & [1] "R-Oxy" tank
504	30005	Carrying stand with wheels for [1] "MC" or "B" tank & [1] "R-Oxy" or "R40" tank
510	30007	Carrying stand with utility tray for [1] "MC" tank or [2] disposable fuel cylinders and [1] "R-Oxy" tank
511	30008	Molded blue plastic carrying stand for [1] "MC" tank or [1] disposable fuel cylinder and [1] "R-Oxy" tank
512	30009	Carrying stand for [2] disposable fuel cylinders or [1] "MC" tank w/utility tray and Air/Fuel handle holder
515	30012	Nitrogen carrying stand for [1] 20 cu. ft. Nitrogen tank
516	30013	Nitrogen carrying stand for [1] 40 cu. ft. Nitrogen tank
517	30014	Nitrogen carrying stand with wheels for [1] 60 cu. ft. tank

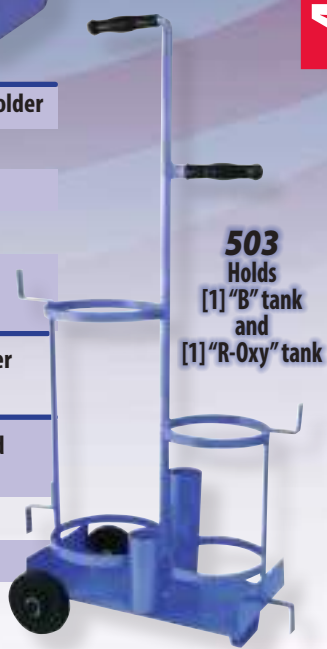

Carrying Stands

Metal

Plastic

Metal



Uniweld Products, Inc. Fort Lauderdale, FL 33312 U.S.A. Customer Service: 800.323.2111
info@uniweld.com • www.uniweld.com

Wrenches/Goggles/Tip Cleaners



Accessories

FOR U.S. JOBS
UNIWELD EMPLOYS OVER 300 WORKERS

Complete selection of combination wrenches for most fittings and connections.



4 Parts & Accessories

Wrenches

Part#	UPC#	Description
W05	43408	Tank key with security chain, fits B and MC tanks
W06	43409	6 way wrench for torches, cylinders and hose connections
W10X	43411	10 way wrench for torches, cylinders and hose connections
W94	43410	B & MC combination wrench for cylinders, torches and "A" size hose nuts

Welding Goggles featuring flip-up #5 tinted lenses and molded-in air vents.



Goggles

Part#	UPC#	Description
WG53	43402	Welding Goggles [type to wear with glasses]

WG53

Aluminum case with tip cleaning data stamped on back. Rust-proof, stainless steel, roll-formed spiral wires. Exclusive LOCK-IN-KNOT on small wires. Tapered pilot ends will not damage tip orifices. A hardened steel file is included. The longer spirals clean a larger number of tip styles.

Tip Cleaners

Part#	UPC#	Description
TCSD	26060	Standard sizes 75-49
TCJD	26062	Jumbo sizes 48-30
TCMD	26064	Master sizes 75-30
TCPD	26061	Propane sizes 67-49, plus 3 blades for spline cleaning
TCLD	26063	Xtra Long sizes 75-49



EXCLUSIVE LOCK-IN-KNOT ON SMALL WIRES

Part#s with D denote hanging display packaging





Flint Lighters/Tool Box

Accessories

FOR U.S. JOBS
UNIWELD EMPLOYS OVER 300 WORKERS

The Uniweld line of accessories shown here and on pages 44 and 45, includes all the "extras" you'll need to work better, faster and safer.



FL34



FL3437



FL35



FL3437TC



FL34D



FL36



FL37



Use Uniweld Flint Lighters to ignite your flame torches. Two styles available. Flint Renewals for both styles in stock.



4 Parts & Accessories

Flint Lighters

Tool Box

Part#	UPC#	Description
FL34	43404	Flint lighter [boxed: 10 units]
FL34D	43437	Flint lighter on display card
FL3437	43403	Flint lighter with 5 flint renewals on card
FL3437TC	43419	Tip cleaner set and flint lighter with 5 flint renewals
FL35	43406	Triple flint lighter on display card
FL36	43407	One 3 flint renewal unit for FL35 lighter
FL37	43405	5 Flint renewal unit for FL34 lighter



CC61



Uniweld Products, Inc. Fort Lauderdale, FL 33312 U.S.A. Customer Service: 800.323.2111
info@uniweld.com • www.uniweld.com

43



Flashback Arrestors/Check Valves/Fittings



Accessories

FOR U.S. JOBS
UNIWELD EMPLOYS OVER 300 WORKERS

Flashback Arrestors quench backfire and flashback at the torch or regulator. Uniweld's Flashback Arrestors also have built-in check valves to prevent reverse flow of gases. They are color coded: Green [Oxygen]; Red [Fuel Gas] and are available for torches and regulators.



RFAB



TFAA



TFAB

FILTERED
3/8" - 24 "A" Fitting

FILTERED
9/16" - 18 "B" Fitting*

Flashback Arrestors	Regulator		Torch		Regulator		Torch	
	Part#	UPC#	Part#	UPC#	Part#	UPC#	Part#	UPC#
Single Oxygen	RFAM100	10211	TFAM100	04061	RFA100	10206	TFA100	04056
Single Fuel	RFAM101	10212	TFAM101	04062	RFA101	10207	TFA101	04057
Set of [2] on card [1] Oxy & [1] Fuel	RFAA	10210	TFAA	04060	RFAB	10205	TFAB	04055

Available for torch and regulator. Flashback arrestors installed at the torch help protect the technician and at the regulator, help protect the equipment. *UL Listed

4 Parts & Accessories

Check Valves

Check Valves provide protection against reverse flow of gases, but not flame flashback. Uniweld's Check Valves conform to OSHA safety standards, [*UL Listed]. They're easy to install, test and service. Color coded: Green [Oxygen]; Red [Fuel Gas].



RVCB

3/8" - 24 "A" Fitting

9/16" - 18 "B" Fitting*

Check Valves	Torch		Regulator		Torch	
	Part#	UPC#	Part#	UPC#	Part#	UPC#
Single Oxygen	TCV10	02651	RCV100	10201	TCV100	04051
Single Fuel	TCV11	02652	RCV101	10202	TCV101	04052
Set of [2] on card [1] Oxy & [1] Fuel	TCVA	02650	RCVB	10200	TCVB	04050

Check valves should be tested regularly for leakage and flow. Check valves on regulators give best service life. ** For "A" outlet regulators, use adaptor F58R or F58L [see page 39] to connect "B" size regulator check valves on small portable outfits. *UL Listed

Swiv-it™ Fittings



HCC38

Swiv-it Fittings

Part#	UPC#	Description
HCC38	43338	3/8" - 24, A-LH, Fuel Gas
HCC38-0	43339	3/8" - 24, A-RH, Oxygen
HCC39	43340	9/16" - 18, B-LH, Fuel Gas
HCC39-0	43341	9/16" - 18, B-RH, Oxygen

- Prevent hose kinks and wrist strain
- Straight pull will uncoil the hoses
- 180° movement on twin hose
- Prevent loosening of hose fittings
- 360° movement on all single hoses
- Pressure tested
- Use on torch or regulator



360° Swivel



Heat Sink Paste/Flame Barrier/Heat Guard



Accessories

FOR U.S. JOBS
UNIWELD EMPLOYS OVER 300 WORKERS

Cool Blue™ Heat Sink Paste protects the rubber and plastic seals in ball valves, solenoid valves, reversing valves and heat sensitive materials. To prevent overheating, a heat transfer cool indicator has been added. As the paste absorbs heat, it changes to a dark blue. Safe to use, non-toxic, harmless to skin and odorless. Easy to clean: wipe with cloth or wash with water.



91861

Part#	UPC#	Description
Cool Blue	91861	Cool Blue™ Heat Sink Paste [Shipped in units of 12 only]

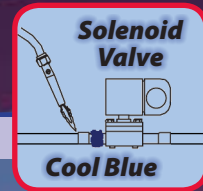
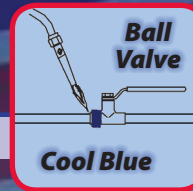

PROTECT SHEETROCK, INSULATION, WOOD, WIRING AND PAINT

FB12

Flame Barrier

A fire resistant material that provides a protective barrier between flammable surfaces and open flames when soldering and brazing. Prevent costly fire damage to wood surfaces, wiring, sheetrock, paint and other surfaces. Flame Barrier will keep its structural integrity up to 2700°F with a melting temperature of 3200°F.

Part#	UPC#	Description
Flame Barrier	FB12	43230 Flame Barrier 12" x 12"



HG-4

Heat Guard

A double layer of stainless steel creates an air gap that guards the surrounding work area against fire damage. The Heat Guard wraps around the pipe, increasing the heat concentration, even in windy conditions. The Heat Guard clips onto the following Uniweld tips: UT4, UT5, UT6, HT44, A11, AS11, T-4, TS-4, LPT4, LPTQ4.

Part#	UPC#	Description
Heat Guard	HG4	43015 Steel Heat Guard



4 Parts & Accessories





Residential/Commercial

Vacuum Pumps

HUMM-VAC®

FOR U.S. JOBS
UNIWELD EMPLOYS OVER 300 WORKERS

The Uniweld exclusive HUMM-VAC® Pumps remove moisture and dehydrate a system quickly and efficiently. The all-metal, heavy duty chassis; powerful, quiet running dual voltage motor; lighter weight and ergonomically designed features make these pumps the #1 choice to go to work with you.



Pump Specifications

HVP6

HVP8

HVP12

	HVP6	HVP8	HVP12
Free Air Displacement	6.0 CFM, 170 liter/min	8.0 CFM, 226 liter/min.	12.0 CFM 340 liter/min.
Number of Stages	2-Stage Rotary Vane	2-Stage Rotary Vane	2-Stage Rotary Vane
Factory Micron Rating	15 Microns	15 Microns	15 Microns
3-Way Intake Fittings	1/4" & 3/8" Male Flare; 1/2" Acme	1/4", 3/8" & 1/2" Male Flare	1/4", 3/8" & 1/2" Male Flare
Thermal Overload Protection	1/2 HP	3/4 HP	3/4 HP
Voltage	110/220V - 50/60Hz	110/220V - 50/60Hz	110/220V - 50/60Hz
Oil Capacity	1 Quart [946ml]	31.3 Ounces [925 ml]	27.7 Ounces [820 ml]
Power Cord*	72" [1.83m], U.S. -Type B Plug	72" [1.83m], U.S. -Type B Plug	72" [1.83m], U.S. -Type B Plug
Dimensions	14.50" x 6.875" x 10.75" 36.83 cm x 17.46 cm x 27.30 cm	15.0" x 6.875" x 10.75" 38.1 cm x 17.46 cm x 27.3 cm	15.0" x 6.875" x 10.75" 38.1 cm x 17.46 cm x 27.3 cm
Weight	26 lbs. [11.80 kg]	34 lbs. [15.42 kg]	35 lbs. [15.88 kg]
Shipping Weight	30 lbs. [13.60 kg]	38 lbs. [17.24 kg]	39 lbs. [17.70 kg]
Color	Yellow	Red	Black

5 HVAC/R TOOLS

HUMM-VAC® Pumps

*Optional Int'l Power Cord Available on request

46



Uniweld Products, Inc. Fort Lauderdale, FL 33312 U.S.A. Customer Service: 800.323.2111
info@uniweld.com • www.uniweld.com

5.5 CFM/1.5 CFM



Vacuum Pumps

FOR U.S. JOBS
UNIWELD EMPLOYS OVER 300 WORKERS

Uniweld's high-performance UVP5 Vacuum Pump has been designed and engineered to provide you with reliable service and the latest in vacuum pump technology. The UVP5 (5.5CFM) pump is built for deep vacuum service on automotive, residential and commercial A/C systems using CFC, HCFC, and HFC refrigerants in conjunction with mineral oil, ester oil, alkybenzene oil and PAG oil as lubricants.

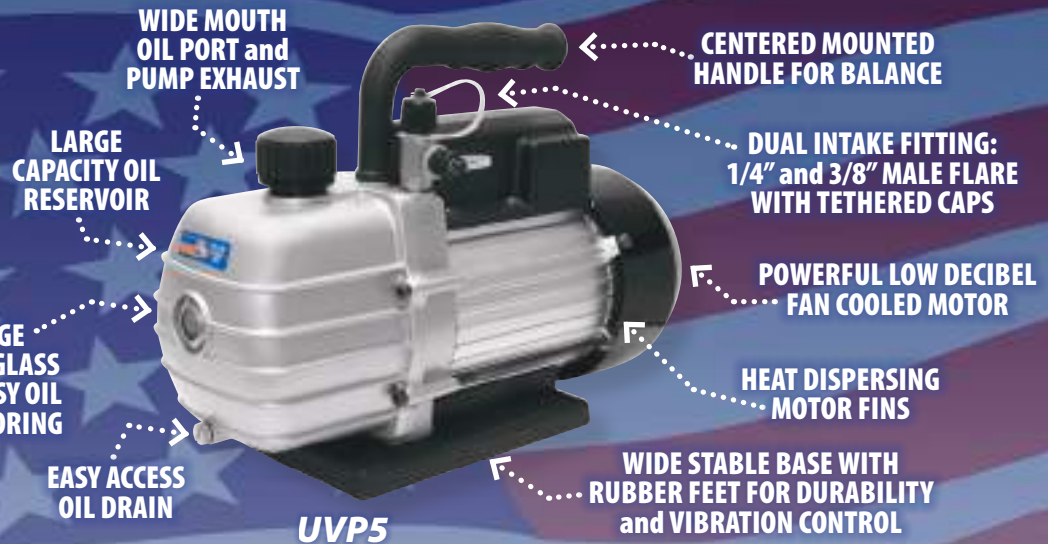

UVP5

Part#	Free Air Displacement		Number of Stages	Factory Micron Rating	Intake Fittings [SAE]	Motor H.P.	Motor RPM	Voltage	Power Cord 72" [1.83m]		Oil Capacity	Dimensions Inches [cm]			Weight Lbs. [Kg]	
	CFM	L/Min							Plug Type	L		W	H	Net	Shi	
UVP5	5.5	155	2	15	1/4" and 3/8" Male Flare	1/2	3440	115V 60Hz	U.S. -Type B	15.22 Oz. [450 ml]	13.9 [35.3]	5.5 [14]	10.2 [26]	22.05 [10]	25.20 [11.4]	
UVP5-220	4.66	132	2	15	1/4" and 3/8" Male Flare	1/2	2880	220V 50Hz	Europe -Type F	15.22 Oz. [450 ml]	13.9 [35.3]	5.5 [14]	10.2 [26]	22.05 [10]	25.20 [11.4]	

Ductless Mini-Split 1.5 CFM Vacuum Pump

The UVP1.5 (1.5CFM) pump is built for deep vacuum service on Ductless Mini-Splits and Automotive A/C Systems. A reliable mini-pump providing the latest in vacuum pump technology.



UVP1.5

Part#	Free Air Displacement		Number of Stages	Factory Micron Rating	Intake Fittings [SAE]	Motor H.P.	Voltage	Power Cord 72" [1.83m]		Oil Capacity	Dimensions Inches [cm]			Weight Lbs. [Kg]	
	CFM	L/Min						Plug Type	L		W	H	Net	Ship	
UVP1.5-110	1.43	40.5	2	38	1/4" Male Flare and 1/2" Acme	1/4	110V 50/60Hz	U.S. -Type B	4.7 Oz. [140 ml]	10.23 [26.0]	3.5 [9.0]	6.4 [16.5]	10 [4.5]	14 [6.3]	
UVP1.5-220	1.43	40.5	2	38	1/4" Male Flare and 1/2" Acme	1/4	220V 50/60Hz	Europe -Type F	4.7 Oz. [140 ml]	10.23 [26.0]	3.5 [9.0]	6.4 [16.5]	10 [4.5]	14 [6.3]	



Uniweld Products, Inc. Fort Lauderdale, FL 33312 U.S.A. Customer Service: 800.323.2111 info@uniweld.com • www.uniweld.com

47

5 HVAC/R Tools

Replacement Parts for HVP6, HVP8, HVP12, UVP5 and UVP1.5



Vacuum Pumps

FOR U.S. JOBS
UNIWELED EMPLOYS OVER 300 WORKERS



Ref#	Part#	Description
1	42250	Exhaust Dome with O-Ring for UVP1.5 & UVP5 [Thread Conn. M27 x 1.5]
2	42251	Exhaust Dome with O-Ring for HVP6, HVP8 & HVP12 [Thread Conn. M27 x 1.5]
3	42252	Oil Drain Fitting with O-Ring for HVP6, HVP8 & HVP12
4	42253	Gas Ballast with O-Ring for HVP6, HVP8 & HVP12
5A	42277	Intake Fit. [1/4" X 1/2" Acme X 3/8"] w/Tethered Caps for HVP6
5B	42278	Intake Fit. [1/4" X 3/8" X 1/2"] w/Tethered Caps for HVP8 & HVP12
6	42257	Chassis Base with Bolt [Set of Two] HVP6
6	42258	Chassis Base with Bolt [Set of Two] HVP8
6	42259	Chassis Base with Bolt [Set of Two] HVP12
7	42260	Base Rubber Feet with Bolt and Washer [set of two] for HVP6, HVP8 & HVP12
8	42261	Electrical On/Off Rocker Switch for HVP6, HVP8 & HVP12
9	42262	Voltage Slide Switch for HVP6, HVP8 & HVP12
10	42263	Power Box Outlet for HVP6, HVP8 & HVP12
11	42264	6' Power Cord (U.S.-Type B Plug) for HVP6, HVP8 & HVP12
12	42265	Handle w/Rubber Grip + [4 bolts] HVP6
12	42266	Handle w/Rubber Grip + [4 bolts] HVP8
12	42267	Handle w/Rubber Grip + [4 bolts] HVP12

Ref#	Part#	Description
13	42274	Oil Reservoir w/Slight Glass + [4bolts] HVP6
13	42275	Oil Reservoir w/Slight Glass + [4bolts] HVP8
13	42276	Oil Reservoir w/Slight Glass + [4 bolts] HVP12
14	42280	Oil Reservoir w/Sight Glass + [4 bolts] UVP5
15A	42281	Intake Fittings [1/4" & 3/8"] w/Tethered Caps, Ball, Snap Rings & Filter for UVP5
15B	VP87	Intake Fittings [1/4" & 1/2" ACME] w/Tethered Caps for UVP1.5
16	42282	Oil Drain Fitting with O-Ring for UVP5 & UVP1.5
17	42283	Platform Base with Rubber Feet for UVP5
18	42284	Handle for UVP5
19A	42285	Electrical On/Off Rocker Switch for UVP5
19B	VP86	Electrical On/Off Rocker Switch for UVP1.5
20	42286	Metal Fan Cover for UVP5
21A	42288	6' Power Cord (U.S. - Type B Plug) for UVP5 & UVP1.5
22B	42289	6' Power Cord (EUROPE - Type F Plug) for UVP5 & UVP1.5-220
23	42268	Black Plastic Power Box for HVP6, HVP8 & HVP12
24	42269	Black Plastic Power Box for UVP5
25	42313	Motor Start Capacitor for UVP5, HVP6, HVP8 & HVP12

Humm-Vac Repair Kits

HVP6RK Kit Includes: (2) Back Rotary Vane (17x23), (2) Front Rotary Vane (28x23), (4) Rotary Vane Spring, (1) Trap Intake O-Ring, Red, (1) Trestle Trap O-Ring, (1) Shaft Seal, (1) Oil Reservoir O-Ring, (2) Exhaust Valve

HVP8RK Kit Includes: (2) Back Rotary Vane (17x26), (2) Front Rotary Vane (30x26), (4) Rotary Vane Spring, (1) Trap Intake O-Ring, Red, (1) Trap Intake O-Ring, Black, (1) Trestle Trap O-Ring, (1) Shaft Seal, (1) Oil Reservoir O-Ring, (3) Exhaust Valve

HVP12RK Kit Includes: (2) Back Rotary Vane (17x26), (2) Front Rotary Vane (40x26), (4) Rotary Vane Spring, (1) Trap Intake O-Ring, Red, (1) Trap Intake O-Ring, Black, (1) Trestle Trap O-Ring, (1) Shaft Seal, (1) Oil Reservoir O-Ring, (3) Exhaust Valve

Vacuum Pump Oil

Uniweld's Vacuum Pump Oil is refined with excellent thermal stability for maximum efficiency in any vacuum pump.

For maximum pump performance, it is recommended that the oil be changed after every evacuation. Severely hydrotreated paraffinic ISO Viscosity Grade 46.



Part#	Description	Part#	Description
Vacuum Pump Oil	42005 1 Quart [946 ml]	42006	1 Gallon [3.78 L]



A/C & R System Evacuation



MaxEvac Kit and Valve Core Removal

FOR U.S. JOBS
UNIWELD EMPLOYS OVER 300 WORKERS

The MaxEvac Kit creates a closed system with unrestricted flow for fast, efficient evacuation of an A/C & R system. This kit includes two Valve Core Removal Tools used to remove the access-fitting valve core for unrestricted evacuation and also to isolate the micron gauge to accurately check the system for vacuum. Compatible with all refrigerants, including R-410A.

MaxEvac Kit



Part#	Description
92822	MaxEvac Kit Includes One of Each: 92825, 92838, H06A404A
92869	R-410A Mini Split MaxEvac Kit Includes One of Each: 92867, 92868 and H06A404A
H06A404A	6" Micron Gauge Vacuum Service Hose, 1/4" F.F. X L45, Black

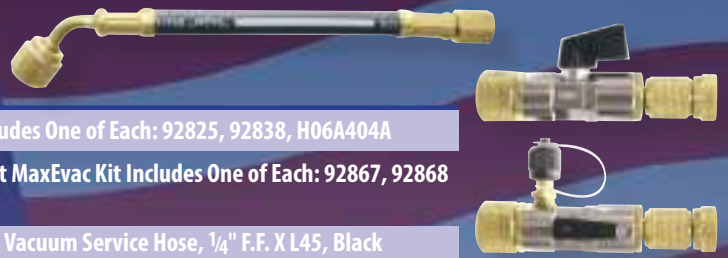

Valve Core Removal

Remove and replace valve cores without losing the system's refrigerant charge using Uniweld's Valve Core Removal Tool. Now you can temporarily remove valve cores for unrestricted line flow, providing faster recovery, evacuation and recharge of a system. The 3/8" full flow ball valve, with positive 1/4 turn on/off, swivels 360° for easy access to the system service valves. Attach and isolate a micron gauge at the system using the Valve Core Removal Tool with 1/4" side port adaptor. Compatible with all refrigerants, including R-410A.



92825
Valve Core Removal Tool with Extractor Rod

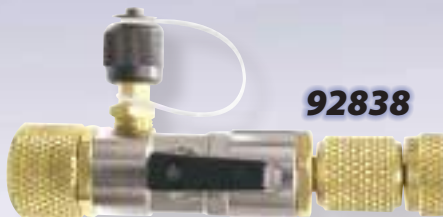

92838
Valve Core Removal Tool with Extractor Rod and 1/4" Side Port Fitting

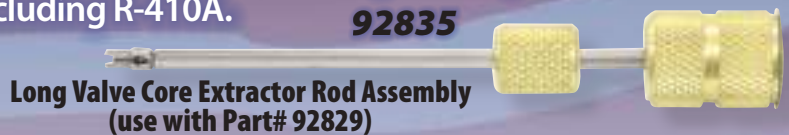

92835
Long Valve Core Extractor Rod Assembly (use with Part# 92829)



92834
Valve Core Extractor Rod Assembly

Part#	Description
92825	Valve Core Removal Tool [1/4"]
92829	R-134a Automotive Adaptors, 1 each [High Side and Low Side]
92832	R-134a Automotive Valve Core Removal Tool Kit includes one of each: 92825, 92829 and 92835
92835	Long Valve Core Extractor Rod Assembly with Storage Compartment
92838	Valve Core Removal Tool with 1/4" Side Port Fitting
92867	R-410A Mini Split 5/16" Valve Core Removal Tool
92868	R-410A Mini Split 5/16" Valve Core Removal Tool with 1/4" Side Port Fitting



92829
R-134a Automotive Adaptors (requires Part# 92835)



Uniweld Products, Inc. Fort Lauderdale, FL 33312 U.S.A. Customer Service: 800.323.2111
info@uniweld.com • www.uniweld.com

49

5 HVAC/R Tools

Electronic Refrigerant Scale



ChargeTron®

FOR U.S. JOBS
UNIWELD EMPLOYS OVER 300 WORKERS

Now you can accurately weigh and transfer refrigerant to and from the A/C system. You will be working with a compact, battery powered, portable (7.2 lbs) workstation that has the cast aluminum scale built right into its high impact plastic carrying case. The optional charging module plugs into the scale to automatically transfer a preset amount of refrigerant.

LCD DISPLAYS
POUNDS/OUNCES OR
KILOGRAMS/GRAMS

OPTIONAL CHARGING MODULE



PART #53651 HAS
ADDITIONAL 120V AC
POWER OUTLET



53650

5 HVAC/R Tools

Tare Weight:	Zeros out scale at any time.
Power:	9 Volt Alkaline Battery. Auto power off: after 15 minutes of operation without any change in weight, scale turns off. Approximately 48 hours battery life. Optional A/C Power Adaptor.
Two Weight Capacities:	110 lbs. [50 Kg] or 176 lbs. [80 Kg]
Accuracy:	At 110 lbs./50 Kg Capacity: ± 0.2 oz./10g • At 176 lbs./80 Kg Capacity: ± 0.5 oz./20g
Weight:	7.2 lbs. [3.26 Kg]
Dimensions:	15" X 13" X 3 $\frac{3}{8}$ " [38cm x 28cm x 8.5cm]
Operating Temperature:	32 °F to 120 °F [0 °C to 50 °C]
Case:	Rugged Plastic Carrying Case with a built-in handle.
Platform Size:	9" X 9" [23cm x 23cm] Ribbed Rubber Mat.
Optional Accessories:	Part# 53651 Automatic Charging Module. Compatible with all refrigerants including R-410A. Maximum working pressure: 300 psi. Part# 53654 Automatic Charging Module. 220V model [no additional power outlet] Compatible with all refrigerants, including R-410A. Maximum working pressure: 300 psi Part# 53652 120V AC Power Adapter connects to ChargeTron® Refrigerant Scale.

50



Uniweld Products, Inc. Fort Lauderdale, FL 33312 U.S.A. Customer Service: 800.323.2111
info@uniweld.com • www.uniweld.com

Visible Vapor Charging Device



Vapor-Vue®

FOR U.S. JOBS
UNIWELD EMPLOYS OVER 300 WORKERS

Absorbs heat naturally and flashes the liquid refrigerant from the cylinder and charges into the system as a vapor. Connecting the Vapor-Vue® to the low side of your charging manifold will increase the charging rate up to 8 times faster and the liquid is controlled by adjusting the manifold valve and monitoring the vapor rate through the double sight glass. Vapor-Vue® is factory pressure tested at 800 psi and can be used to charge any refrigeration & air conditioning system using R-410A, CFC, HCFC & HFC; Zeotropic and Azeotropic refrigerants without the danger of liquid slugging and damaging the compressor. Placing the manifold & Vapor-Vue® over hot discharge airflow of the condensing unit will increase the heat exchange and charging rate efficiency. Patent Pending.



VV1

Part#	Description
VV1	Vapor-Vue with 1/4" Flare Fittings - HVAC/R



Liquid Refrigerant to Vapor

A/C Flush Kit

The A/C Flush Kit is ideal for system flushing after compressor burnouts and will remove contaminants, moisture and acid from the evaporator and condenser. It is also used during retrofits and flushing R-22 line sets for R-410A conversions. The R-22 mineral oil based system is not compatible with the R-410A ester oil based system.

Special design features include:

- Pressure Relief Valve that opens at 180 to 190 PSI to protect the cylinder and equipment from overpressure.
- Blowgun with rubber tip nozzle for copper tubing 3/8" to 1 1/8" O.D.
- Reusable canister holds up to 18 oz.

Part#	Description
94184	A/C System Flush Kit
H2SSM	24" Service Hose
FG24A	A/C Rubber Tip Nozzle with 1/8" M.P.T. Fitting
BG1ACA	Blowgun with A/C Rubber Tip Nozzle

Reseatable Pressure Relief Valve Patent# 8,181,665



94184

1/4" Male Flare

Automotive A/C Flush Kit also available (see page 70)

Actuating Valve



AV25H

For use on disposable flush solvent cylinders with 1/2"-16 Acme connection. Safety Check valve built in the 1/4" M.F. outlet connection prevents pressurizing the disposable cylinder.



2 Valve Aluminum Manifold with 3 1/8" NPF® Gauges



SPiRiT™ R-410A/R-22/R-404A/R-134a Manifold

FOR U.S. JOBS
UNIWELD EMPLOYS OVER 300 WORKERS

COLOR CODED GAUGE BOOTS



R-410A/R-22
R-404A/R-134a
3 1/8" Replacement
Gauges
#G429ND Red,
Pressure
#G430ND Blue,
Compound

USAM

The all new SPiRiT MANIFOLD! designed and built right here in the U.S.A., proudly emphasizes the quality and the superior workmanship that signifies American Made. Lightweight extruded aluminum body and easy-grip handles for positive control; double O-ring piston valve for long reliable service; easy access front hose holders; large easy-to-read 3 1/8" steel case NPF™ gauges with color-coded protective boots; 5' High Pressure Soft Magic® Barrier Hose set with optional EZ-Turn anti-blowback or ball valve fittings.

5 HVAC/R Tools



Part#	UPC#	Description
USAM	49200	2-Valve Aluminum Manifold [No Hoses]
USAM3HEZ	49211	2-Valve Aluminum Manifold with 3ft. EZ-Turn Anti-Blowback Hose Set
USAM5HEZ	49212	2-Valve Aluminum Manifold with 5ft. EZ-Turn Anti-Blowback Hose Set
USAM6HEZ	49213	2-Valve Aluminum Manifold with 6ft. EZ-Turn Anti-Blowback Hose Set
USAM3HBV	49271	2-Valve Aluminum Manifold with 3ft. Ball Valve Hose Set
USAM5HBV	49272	2-Valve Aluminum Manifold with 5ft. Ball Valve Hose Set
USAM6HBV	49273	2-Valve Aluminum Manifold with 6ft. Ball Valve Hose Set

Other pressure and temperature scales are available upon request.

52



Uniweld Products, Inc. Fort Lauderdale, FL 33312 U.S.A. Customer Service: 800.323.2111
info@uniweld.com • www.uniweld.com

4 Valve Aluminum Manifold with 3 1/8" NPF® Gauges



Man, What a Manifold®

R-410A/R-22/R-404A/R-134a

FOR U.S. JOBS
UNIWELD EMPLOYS OVER 300 WORKERS



Lens Plug
for easy
zero reset



Q4N85SMA

Q4N8

NPF®
Silicone
Dampened
Movement



Anodized aircraft aluminum block body with 4 ports for charging, evacuating and testing a system without changing or removing hoses • 3/8" SAE port increases vacuum capacity and saves time • Optical sight glass for monitoring refrigerant • Durable, brazed brass T-handles provide smooth, precise adjustments • NPF® No Pointer Flutter® 3 1/8" gauges with color coded refrigerant scales and color coded gauge boots • High Pressure Soft Magic® Barrier Hoses [available with optional EZ-Turn anti-blowback fittings]. Man, What a Manifold!



R-410A/R-22/R-404A/R-134a
Replacement Gauges 3 1/8" [80mm]
#G429ND Red, Pressure
#G430ND Blue, Compound

Part# UPC# Description R-410A/R-22/R-404A/R-134a- PSI/°F

Q4N8	48700	4-Valve Aluminum Manifold [No Hoses]
Q4N85SM	48701	4-Valve Aluminum Manifold with 5ft. Soft Magic® Barrier Hose Set
Q4N85MEZ	48721	4-Valve Aluminum Manifold with 5ft. Soft Magic® Barrier EZ-Turn Anti-Blowback Hose Set

Other pressure and temperature scales are available upon request.



Uniweild Products, Inc. Fort Lauderdale, FL 33312 U.S.A. Customer Service: 800.323.2111
info@uniweild.com • www.uniweild.com

53

5 HVAC/R Tools



2 Valve Brass Manifold with 3 1/8" NPF® Gauges

Man, What a Manifold®

FOR U.S. JOBS
UNIWELD EMPLOYS OVER 300 WORKERS

R-410A/R-22/R-404A/R-134a

COLOR CODED GAUGE BOOTS

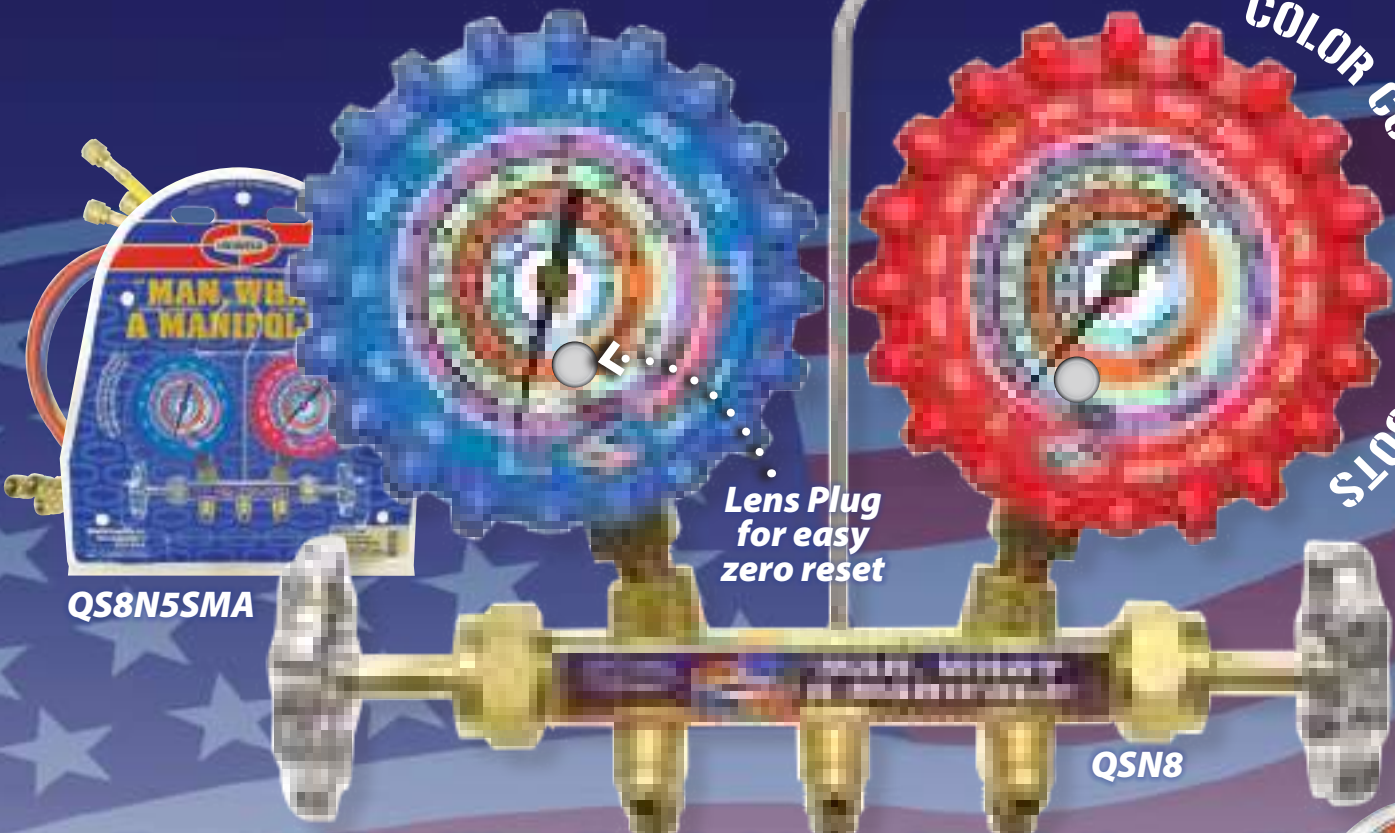

QS8N5SMA

Lens Plug for easy zero reset

QS8N

The patented Uniweld forged brass body is manufactured with reseatable Teflon® valve stem packing for durability and leakproof reliability. These user-friendly, accurate, manifolds feature: • NPF® No Pointer Flutter® 3 1/8", easy-to-read gauges with color coded refrigerant scales and color coded gauge boots • Metal [not plastic] hand wheels • Extended valve stems for ample knuckle clearance • Quick action valve assembly for 1/2 turn fully open or fully closed • Convenient 45° front hose holders • High Pressure Soft Magic® Barrier Hoses with EZ-Turn anti-blowback fittings. Man, What a Manifold!

NPF®
Silicone Dampened Movement

5 HVAC/R Tools



Part#	UPC#	Description	R-410A/R-22/R-404A/R-134a-PSI/°F
QS8N	48600	2-Valve Brass Manifold [No Hoses]	
QS8N3SMEZ	48671	2-Valve Brass Manifold with 3ft. EZ-Turn Anti-Blowback Hose Set	
QS8N5SMEZ	48672	2-Valve Brass Manifold with 5ft. EZ-Turn Anti-Blowback Hose Set	
QS8N6SMEZ	48673	2-Valve Brass Manifold with 6ft. EZ-Turn Anti-Blowback Hose Set	

Other pressure and temperature scales are available upon request.

R-410A/R-22/R-404A/R-134a
Replacement Gauges 3 1/8" [80mm]
#G429ND Red, Pressure
#G430ND Blue, Compound

54



Uniweld Products, Inc. Fort Lauderdale, FL 33312 U.S.A. Customer Service: 800.323.2111
info@uniweld.com • www.uniweld.com



2 Valve Brass Manifold with 2½" LPF™ Gauges

Man, What a Manifold®

FOR U.S. JOBS
UNIWELED EMPLOYS OVER 300 WORKERS

COLOR CODED
GAUGE BOOTS

R-410A/R-22/R-404A



QS4L5H



QS4L



Vapor-Vue® Charging Device connects to low side (see page 51)

The patented Uniweld forged brass body is manufactured with reseatable Teflon® valve stem packing for durability and leakproof reliability. This user-friendly, accurate, manifold features: • Limited Pointer Flutter™, easy-to-read 2½" gauges with color coded refrigerant scales and color coded gauge boots • Metal [not plastic] hand wheels • Extended valve stems for ample knuckle clearance • Quick action valve assembly for ½ turn fully open or fully closed • Convenient 45° front hose holders • High Pressure Soft Magic® Barrier Hoses (available with optional EZ-Turn anti-blowback fittings). Man, What a Manifold!

Part#	UPC#	Description	R-410A/R-22/R-404A-PSI/°F
QS4L	47500	2-Valve Brass Manifold [No Hoses]	
QS4L3H	47501	2-Valve Brass Manifold with 3ft. Soft Magic® Barrier Hose Set	
QS4L5H	47502	2-Valve Brass Manifold with 5ft. Soft Magic® Barrier Hose Set	
QS4L6H	47503	2-Valve Brass Manifold with 6ft. Soft Magic® Barrier Hose Set	
QS4L3HEZ	47411	2-Valve Brass Manifold with 3ft. Soft Magic® Barrier EZ-Turn Anti-Blowback Hose Set	
QS4L5HEZ	47412	2-Valve Brass Manifold with 5ft. Soft Magic® Barrier EZ-Turn Anti-Blowback Hose Set	
QS4L6HEZ	47413	2-Valve Brass Manifold with 6ft. Soft Magic® Barrier EZ-Turn Anti-Blowback Hose Set	

Other pressure and temperature scales are available upon request.



R-410A/R-22/R-404A Replacement Gauges
#G529LD Red, Pressure
#G530LD Blue, Compound



Uniweld Products, Inc. Fort Lauderdale, FL 33312 U.S.A. Customer Service: 800.323.2111
info@uniweld.com • www.uniweld.com

55

5 HVAC/R Tools



2 Valve Brass Manifold with 2 1/2" LPF™ Gauges

Man, What a Manifold®

FOR U.S. JOBS
UNIWELD EMPLOYS OVER 300 WORKERS

R-22/R-404A/R-134a

COLOR CODED GAUGE BOOTS



QAL5SM



QAL

The patented Uniweld forged brass body is manufactured with reseatable Teflon® valve stem packing for durability and leakproof reliability. This user-friendly, accurate, manifold features: • Limited Pointer Flutter™, easy-to-read 2 1/2" gauges with color coded refrigerant scales and color coded gauge boots • Metal [not plastic] hand wheels • Extended valve stems for ample knuckle clearance • Quick action valve assembly for 1/2 turn fully open or fully closed • Convenient 45° front hose holders • High Pressure Soft Magic® Barrier Hoses (available with optional EZ-Turn anti-blowback fittings). Man, What a Manifold!

5 HVAC/R TOOLS

Part#	UPC#	Description	R-22/R-404A/R-134a-PSI/°F
QAL	45050	2-V Brass Manifold [No Hoses]	
QAL3SM	48001	2-V Brass Manifold with 3ft. Soft Magic® Hose Set	
QAL5SM	48002	2-V Brass Manifold with 5ft. Soft Magic® Hose Set	
QAL6SM	48003	2-V Brass Manifold with 6ft. Soft Magic® Hose Set	
QAL3SMEZ	48171	2-V Brass Manifold with 3ft. Soft Magic® EZ-Turn Anti-Blowback Hose Set	
QAL5SMEZ	48172	2-V Brass Manifold with 5ft. Soft Magic® EZ-Turn Anti-Blowback Hose Set	
QAL6SMEZ	48173	2-V Brass Manifold with 6ft. Soft Magic® EZ-Turn Anti-Blowback Hose Set	



R-22/R-404A/R-134a Replacement Gauges #G29LD Red, Pressure #G30LD Blue, Compound

Other pressure and temperature scales are available upon request.



Replacement Parts for 2 Valve and 4 Valve Manifolds



Man, What a Manifold®

FOR U.S. JOBS
UNIWELD EMPLOYS OVER 300 WORKERS

2 Valve Brass Manifold Replacement Parts

QVK-2
Manifold Valve Repair Kit
[2] Teflon Washers
[2] Teflon Valve Seats



Valve Packing Nut

Teflon Washer (Packing)

Brass Packing Washer

Steel Washer

Valve Stem

Teflon Valve Seat

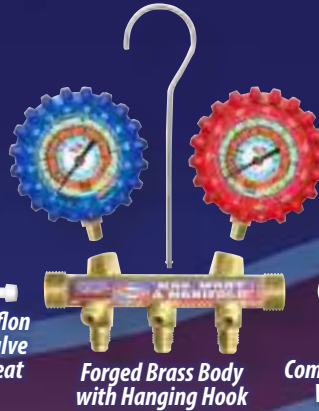

Replacement Gauges
(See pages 58-59)

U.S. Patent No. 6,094,983

QA200A
Complete Metal Handle and Valve Stem Assembly

U.S. Patent No. D453,953

4 Valve Aluminum Manifold Replacement Parts

Replacement Gauges
(See pages 58-59)

Q422-2A
Low Side Handle Assembly

Q422-4A
Vacuum Handle Assembly

10005
Hose Fitting
1/4" SAE

1393-3
Hose Fitting
3/8" SAE

46025
Sight Glass Repair Kit (4 pcs.)
Use 9/16" Hex Wrench

Q414K Valve Seal Repair Kit

Q422A
High Side Handle Assembly

Q422-3A
Refrigerant Handle Assembly

Q408A Hose Bracket Assembly

100X51A4
Hanging Hook and Nut Assembly

Replacement Gauges
(See pages 58-59)

Extruded Aluminum Body

SPR3K
Complete Metal Handle and Valve Stem Assembly

10005
Hose Fittings
1/4" SAE

100X51A4
Hanging Hook and Nut Assembly

EVX38
Retaining Ring (Pkg. of 2)

SPR3A
Valve Stem Assembly

Screw
Lock Washer

2 Valve SPIRIT Manifold Replacement Parts



Uniweld Products, Inc. Fort Lauderdale, FL 33312 U.S.A. Customer Service: 800.323.2111
info@uniweld.com • www.uniweld.com

57

Manifold Replacement Gauges



NPF[®] Gauges

FOR U.S. JOBS
UNIWELD EMPLOYS OVER 300 WORKERS

The original NPF[®] No Pointer Flutter[®] Gauges that provide steady and accurate pressure readings. The encapsulated silicone dampened movement seldom needs recalibration. The gauge is guaranteed not to leak fluid and not to lose dampening characteristics. Scales are printed in refrigerant colors.

COLOR CODED GAUGE BOOTS

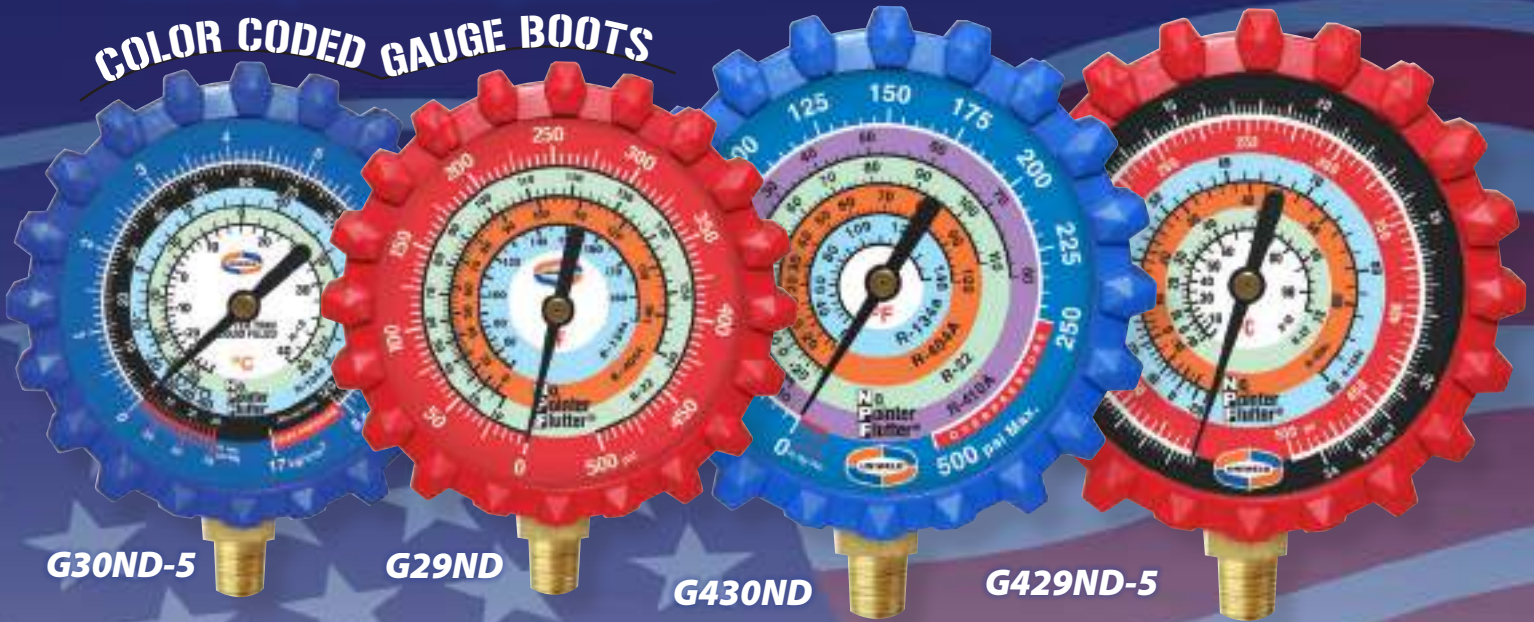

G30ND-5

G29ND

G430ND

G429ND-5



Competitor's "Vibration Free" Gauge



Uniweld's NPF[®] Gauge

Size	Refrigerant Pressure/Temperature Scale	Color Coded Case		Brass Case	
		Red Pressure Part#	Blue Compound Part#	Pressure Part#	Compound Part#
2 1/2"	R-134a/R-22/R-404A PSI °F	G29ND	G30ND	G29NBD	G30NBD
	R-134a/R-22/R-12 PSI-kg/cm ² -°F PSI-kg/cm ² -°C	G29ND-1 G29ND-5	G30ND-1 G30ND-5	G29NBD-1 G29NBD-5	G30NBD-1 G30NBD-5
	R-410A/R-22/R-404A PSI °F	G529ND	G530ND	G529NBD	G530NBD
3 1/8" [80mm]	R-134a/R-12 [Automotive] PSI-°F	G409NSAD	G410NSAD		
	R-410A/R-22/R-404A/R-134a PSI-°F	G429ND	G430ND		
	R-134a/R-404A/R-22/R-12 PSI - kg/cm ² °C	G429ND-5	G430ND-5		



NPF[®] Silicone Dampened Movement

Replacement Parts

Part#	UPC#	Description
CF25	51018	2 1/2" Clear Front Lens w/ Plug
CF80	51019	3 1/8" [80mm] Clear Front Lens w/ Plug
GB25S	51027	2 1/2" Protective Gauge Boots, Pkg. [1] Red, [1] Blue
GB80S	51028	3 1/8" [80mm] Protective Gauge Boots, Pkg. [1] Red, [1] Blue
PL25	51004	2 1/2" Posi-Lock Replacement Lens



GB80S

5 HVAC/R TOOLS

58



Uniweld Products, Inc. Fort Lauderdale, FL 33312 U.S.A. Customer Service: 800.323.2111
info@uniweld.com • www.uniweld.com

Manifold Replacement Gauges



LPF™ Gauges

FOR U.S. JOBS
UNIWELD EMPLOYS OVER 300 WORKERS

Uniweld's 2 1/2" LPF™ Limited Pointer Flutter™ Gauges with large, easy-to-read dial faces provide improved accuracy of pressure readings. Features include a high torque hair spring movement and a special pulsation dampener.

COLOR CODED GAUGE BOOTS

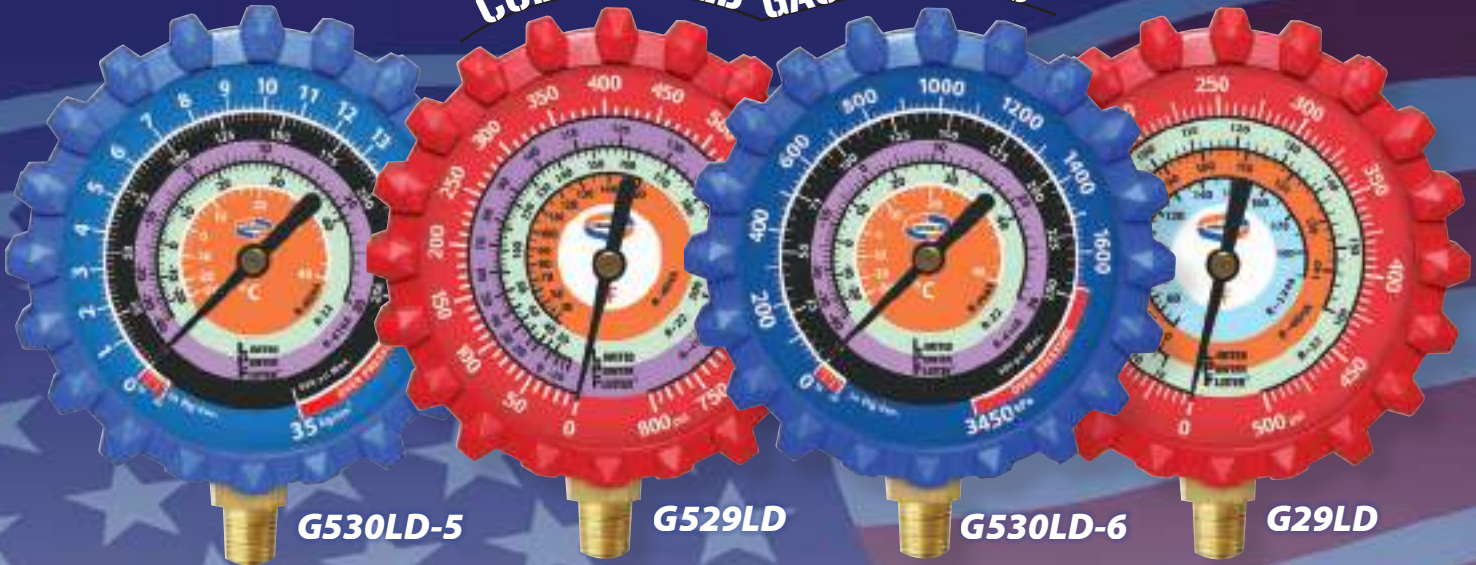

Competitor's "Vibration Free" Gauge



Uniweld's LPF™ Gauge

Size	Refrigerant Pressure/Temperature Scale	Color Coded Case		Brass Case	
		Red Pressure Part#	Blue Compound Part#	Pressure Part#	Compound Part#
2 1/2"	R-22/R-404A/R-134a PSI °F	G29LD	G30LD	G29D	G30D
	R-134a /R-12/R-22 PSI-Kg/cm ² -°F PSI-Kg/cm ² -°C	G29LD-1 G29LD-5	G30LD-1 G30LD-5	G29D-1 G29D-5	G30D-1 G30D-5
	R-410A/R-22/R-404A PSI °F PSI-Kg/cm ² -°C PSI-kPa °C	G529LD G529LD-5 G529LD-6	G530LD G530LD-5 G530LD-6	G529D -	G530D -
	R-134a/R-12 [Automotive] PSI-°F	G9LAD	G10LAD	-	-
	R-134a/R-404A/R-507 PSI-Kg/cm ² -°C	G9LD-5	G10LD-5	-	-



Replacement Parts

Part#	UPC#	Description
CF25	51018	2 1/2" Clear Front Lens w/ Plug
GB25S	51027	2 1/2" Protective Gauge Boots, Pkg. [1] Red, [1] Blue
PL25	51004	2 1/2" Posi-Lock Replacement Lens

GB25S



Uniweld Products, Inc. Fort Lauderdale, FL 33312 U.S.A. Customer Service: 800.323.2111
info@uniweld.com • www.uniweld.com

59

5 HVAC/R Tools



Premium flexible barrier hose with standard fittings

Soft Magic® Barrier Hose

Rated for R-410A, CFC, HCFC
and HFC refrigerants

FOR U.S. JOBS
UNIWELD EMPLOYS OVER 300 WORKERS

**RATED FOR
R-410A
*2 YEAR
WARRANTY**



Standard Fitting
(actual size)

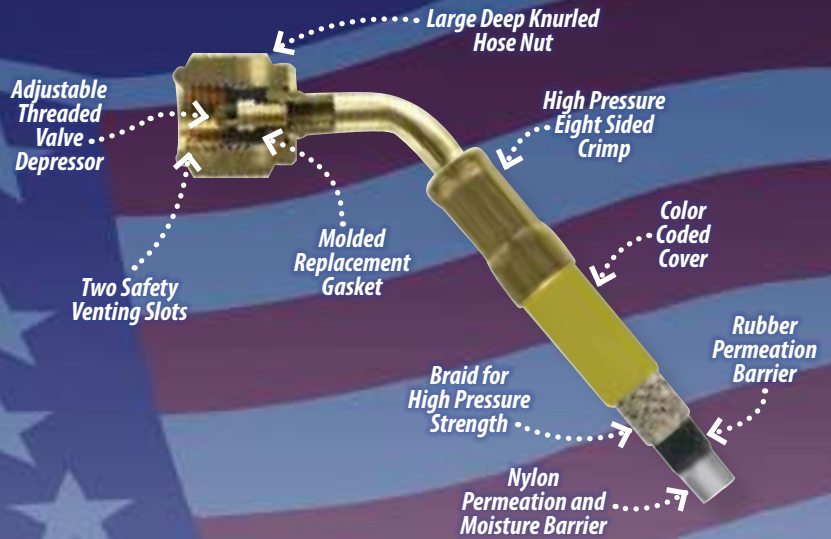

Maximum Working Pressure: 800 PSI
Burst Pressure: 4000 PSI

	Length		Red	Yellow	Blue	Hose Set 1 Each R, Y, B Part#
			Part#	Part#	Part#	
Soft Magic® Barrier Hoses with Standard Fittings	6"	15cm	H06SMBR	H06SMBY	H06SMBB	HC353SMB Hose Set: [2] 3 ft. hoses and [1] 5 ft. Hose
	12"	30cm	H1SMBR	H1SMBY	H1SMBB	
	24"	60cm	H2SMBR	H2SMBY	H2SMBB	
	36"	90cm	H3SMBR	H3SMBY	H3SMBB	HC3SMB
	48"	120cm	H4SMBR	H4SMBY	H4SMBB	HC4SMB
	60"	150cm	H5SMBR	H5SMBY	H5SMBB	HC5SMB
	72"	180cm	H6SMBR	H6SMBY	H6SMBB	HC6SMB
	96"	240cm	H8SMBR	H8SMBY	H8SMBB	HDC5MB Hose Set: [3] 5 ft. 1/4" Hoses and [1] 5 ft. 3/8" Hose
	25'	7.50m	H25SMBR	H25SMBY	H25SMBB	
	50'	15.00m	H50SMBR	H50SMBY	H50SMBB	
	100'	30.00m	H100SMBR	H100SMBY	H100SMBB	

Part#	Description
H1476	Pkg. of (6) Gaskets and (3) Depressors
HX14N-10	Pkg. of (10) Gaskets
HX14N-100	Pkg. of (100) Gaskets
H76S-10	Pkg. of (10) Valve Depressors

See HVAC/R Price List for details.

92655
Soft Magic®
Barrier Hose
Display Rack
(Holds up to
50 Hoses)



5 HVAC/R TOOLS

60



Uniweild Products, Inc. Fort Lauderdale, FL 33312 U.S.A. Customer Service: 800.323.2111
info@uniweild.com • www.uniweild.com

Premium flexible barrier hose with anti-blowback fittings



Soft Magic® Barrier Hose

FOR U.S. JOBS
UNIWELD EMPLOYS OVER 300 WORKERS



EZ Turn Anti-Blowback fitting has a thrust bearing that reduces friction so the service hose can be easily connected to the access fitting while under pressure. Compact design fits in tight work spaces. Deep square knurling and textured orange and blue band for easy fingertip control!

UNDER PRESSURE



RATED FOR R-410A
*2 YEAR WARRANTY

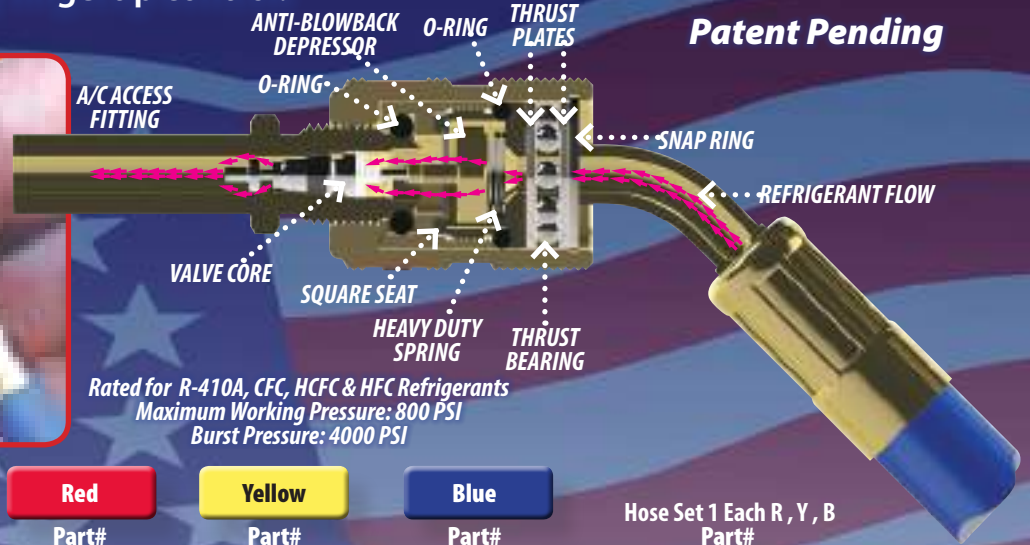

Rated for R-410A, CFC, HCFC & HFC Refrigerants
Maximum Working Pressure: 800 PSI
Burst Pressure: 4000 PSI

Patent Pending

	Length	Red Part#	Yellow Part#	Blue Part#	Hose Set 1 Each R, Y, B Part#
1/4" EZ TURN ANTI-BLOWBACK FITTING	36" 90cm	EZ3R	EZ3Y	EZ3B	EZ3HS
	60" 150cm	EZ5R	EZ5Y	EZ5B	EZ5HS
	72" 180cm	EZ6R	EZ6Y	EZ6B	EZ6HS
	25' 7.50m	EZ25R	EZ25Y	EZ25B	EZ5HDS Hose Set: [3] 5 ft. 1/4" Hoses and [1] 5 ft. 3/8" Hose
	50' 15.00m	EZ50R	EZ50Y	EZ50B	
100' 30.00m	EZ100R	EZ100Y	EZ100B		
R-410A Mini Split 5/16" EZ TURN ANTI-BLOWBACK FITTING (1/4" X 5/16")	36" 90cm	EZM3R	EZM3Y	EZM3B	
	60" 150cm	EZM5R	EZM5Y	EZM5B	
	72" 180cm	EZM6R	EZM6Y	EZM6B	

EZ TURN ANTI-BLOWBACK ADAPTORS

	Part#	Description	EZAB	EZAB90
1/4"	EZAB	Straight 1/4" M.F. x 1/4" F.F.		
	EZAB90	90° 1/4" M.F. x 1/4" F.F.		
5/16" R-410A Mini Split	EZABM	Straight 1/4" M.F. x 5/16" F.F.		
	EZABM90	90° 1/4" M.F. x 5/16" F.F.		
Replacement Parts	Part#	Description		
	EZHRK	Pkg. of (1) Spring • (1) Anti-Blowback Depressor (1) Square Seat • (2) O-Rings (1) Hose Gasket		



EZHR EZ TURN Hose Display Rack (Holds up to 50 Hoses)

5 HVAC/R Tools



Uniweild Products, Inc. Fort Lauderdale, FL 33312 U.S.A. Customer Service: 800.323.2111
info@uniweild.com • www.uniweild.com

61



Premium flexible barrier Ball Valve hose Soft Magic® Barrier Hose

FOR U.S. JOBS
UNIWELD EMPLOYS OVER 300 WORKERS

The Soft Magic® Barrier Ball Valve Hose has our universal ball valve with patented interchangeable service connectors and flex service hoses that connect easily to that hard-to-reach access fitting. Easy-snap-in service connectors available: straight, 45° bend, 90° bend or a 6" service hose. Maximum working pressure is 800 PSI with a burst pressure of 4000 PSI.

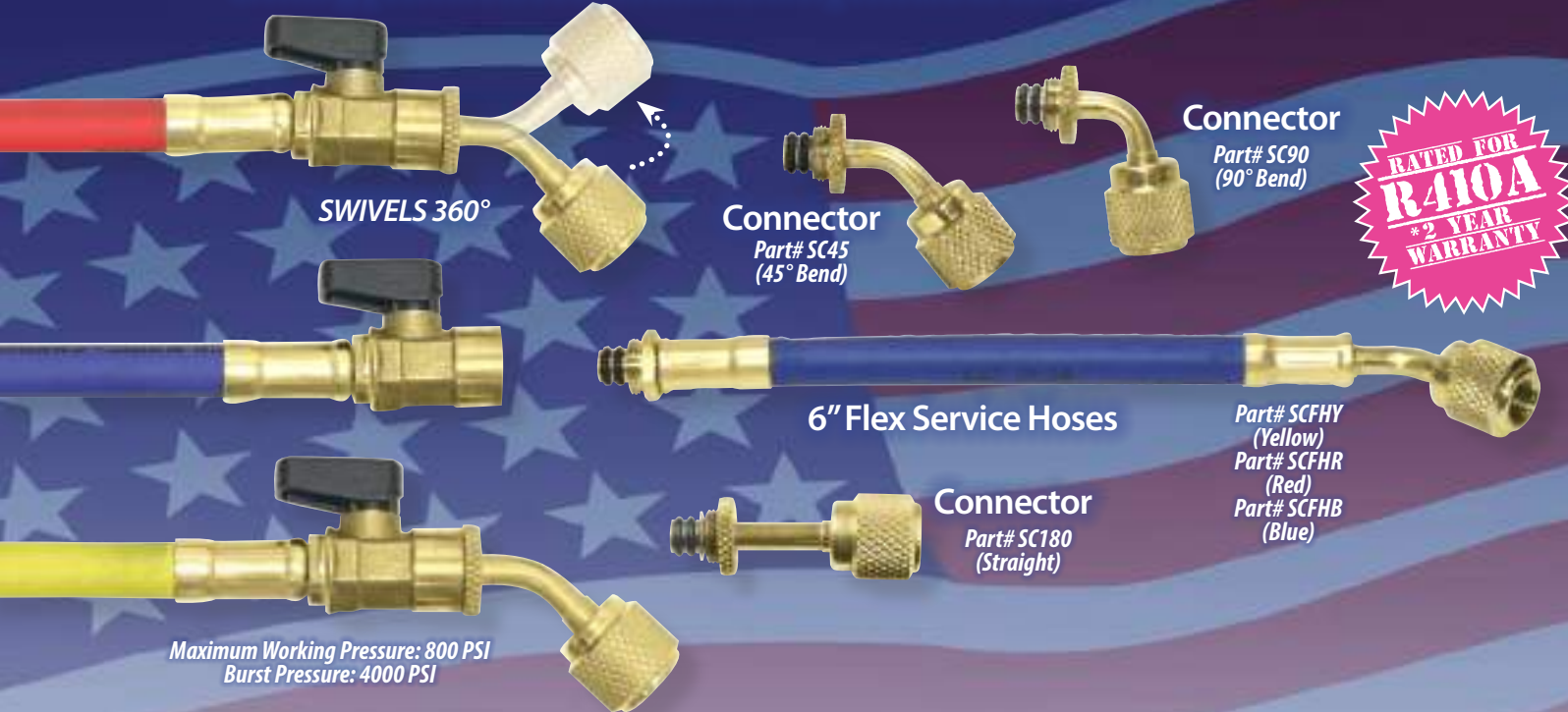

Maximum Working Pressure: 800 PSI
Burst Pressure: 4000 PSI

	Length	Red	Yellow	Blue	Hose Set 1 Each R, Y, B Part#
		Part#	Part#	Part#	
Soft Magic® Barrier Ball Valve Hoses with 45° Bend Service Connector	36" 90cm	H3SMBER	H3SMBEY	H3SMBEB	HC3SMBE
	48" 120cm	H4SMBER	H4SMBEY	H4SMBEB	HC4SMBE
	60" 150cm	H5SMBER	H5SMBEY	H5SMBEB	HC5SMBE
	72" 180cm	H6SMBER	H6SMBEY	H6SMBEB	HC6SMBE
	96" 240cm	H8SMBER	H8SMBEY	H8SMBEB	HC353MBE Hose Set: [2] 3 ft. Hoses and [1] 5 ft. Hose
	25' 7.50m	H25SMBER	H25SMBEY	H25SMBEB	
	50' 15.00m	H50SMBER	H50SMBEY	H50SMBEB	
	100' 30.00m	H100SMBER	H100SMBEY	H100SMBEB	
	Part#	Description			
Repair Kit	21085	Service Connector Repair Kit Includes: [2] O-Rings and [1] Retainer Clip			

5 HVAC/R TOOLS





Inline / Panel Mount / 45° Bend Ball Valve Adaptors

FOR U.S. JOBS
UNIWELD EMPLOYS OVER 300 WORKERS



92806

Inline or Panel Mount Ball Valve Adaptor



92809

45° Bend Ball Valve Adaptor

Minimize refrigerant loss by rotating valve to the closed position before disconnecting from the system. Recovery machine panel mount control valve.

Hose nut swivels 360° for easy access into tight work areas. Add to existing hose as control device.

Part#	Description
92806	Inline or Panel Mount Ball Valve Adaptor, 1/4" M.F. x 1/4" M.F. (Yellow)
92807	Inline or Panel Mount Ball Valve Adaptor, 1/4" M.F. x 1/4" M.F. (Red)
92808	Inline or Panel Mount Ball Valve Adaptor, 1/4" M.F. x 1/4" M.F. (Blue)

Inline or Panel Mount Ball Valve

Part#	Description
92809	Ball Valve Adaptor, 1/4" M.F. x 1/4" M.F. with 45° Bend (Red)
92810	Ball Valve Adaptor, 1/4" M.F. x 1/4" M.F. with 45° Bend (Yellow)
92811	Ball Valve Adaptor, 1/4" M.F. x 1/4" M.F. with 45° Bend (Blue)
92833	Ball Valve Adaptor Set, 1/4" M.F. x 1/4" M.F. with 45° Bend (1 each R, Y, B)

45° Bend Ball Valve Adaptor



90048

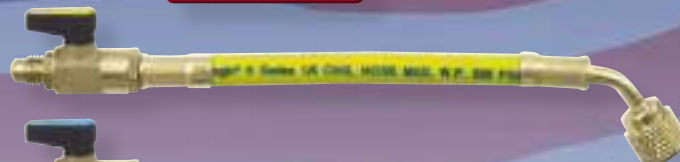

90050

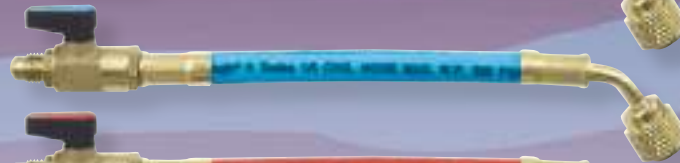

90051



90052



90049



90054

Part#	Description
90048	Inline Ball Valve, 3/8" M.F. x 3/8" M. F.
90049	Inline Ball Valve, 3/8" M.F. x 1/4" M. F.
90054	Ball Valve with 6" Heavy Duty Hose, 3/8" M.F. x 3/8" F.F.
90055	Ball Valve with 6" Standard Hose, 3/8" M.F. x 1/4" F.F. Hose w/45° Bend, Yellow

6" Enviro Adaptor Hoses

Part#	Description
90050	Ball Valve with 6" Hose, 1/4" M.F. x 1/4" F.F. w/45° Bend (Yellow)
90051	Ball Valve with 6" Hose, 1/4" M.F. x 1/4" F.F. w/45° Bend (Blue)
90052	Ball Valve with 6" Hose, 1/4" M.F. x 1/4" F.F. w/45° Bend (Red)
90053	Ball Valve with 6" Hose, 1/4" M.F. x 3/16" F.F. w/45° Bend (Red)
90299	Ball Valve with 6" Hose Set, [1 each 90050, 90051, 90052]



Heavy Duty Charging and Vacuum Hoses



Soft Magic® Hoses

FOR U.S. JOBS
UNIWELD EMPLOYS OVER 300 WORKERS

Premium, large I.D. Hoses for CFC, HCFC and HFC refrigerants. Supplied with large, knurled hose nuts and rubber gaskets for easy finger tightening or wrench tight metal to metal seat hex flare nuts and copper gaskets. Choose from 3/8", 1/2" and 3/4" I.D. hoses to suit your requirements. 2-year over-the-counter replacement warranty*.



Length	Rubber Seat		Metal Seat		
	3/8" Str. x 3/8" Str. Part#	3/8" Str. x 1/4" 45° Part#	3/8" F.F. x 3/8" F.F. Part#	3/8" F.F. x 3/8" F.F. 90° Part#	3/8" F.F. 90° x 3/8" F.F. 90° Part#
6" 15cm	90524	90527	90530	90533	90536
12" 30cm	90525	90528	90531	90534	90537
24" 60cm	90526	90529	90532	90535	90538
36" 90cm	90500	90206	90214	90222	90230
48" 120cm	90501	90207	90215	90223	90231
60" 150cm	90502	90208	90216	90224	90232
72" 180cm	90503	90209	90217	90225	90233
96" 240cm	90504	90210	90218	90226	90234
25' 750cm	90505	90211	90219	90227	90235
50' 1500cm	90506	90212	90220	90228	90236
100' 3000cm	90507	90213	90221	90229	90237

3/8" Soft Magic® Heavy Duty Charging and Vacuum Hose

Max. Work Press: 600 PSI

Burst Press: 3000 PSI

Length	Rubber Seat		Metal Seat		Metal Seat	
	1/2" Str. x 1/2" Str. Part#	5/8" Str. x 5/8" Str. Part#	1/2" F.F. x 1/2" F.F. Part#	5/8" F.F. x 5/8" F.F. Part#	3/4" F.F. x 3/4" F.F. Part#	
36" 90cm	90238	90246	90508	90254		
48" 120cm	90239	90247	90509	90255		
60" 150cm	90240	90248	90510	90256		
72" 180cm	90241	90249	90511	90257		
96" 240cm	90242	90250	90512	90258		
25' 750cm	90243	90251	90513	90259		
50' 1500cm	90244	90252	90514	90260		
100' 3000cm	90245	90253	90515	90261		

1/2" & 3/4" Soft Magic® Heavy Duty Charging and Vacuum Hose

Max. Work Press: 350 PSI

Burst Press: 1987 PSI

3/4" Heavy Duty Charging Hi-Vacuum Hose

Max. Work Press: 350 PSI

Burst Press: 1987 PSI

See HVAC/R Price List for details.



Hex Female Flare Metal to Metal Seat

Replacement Parts

Part#	Description
HDX14N-10	Pkg. of [10] Rubber Gaskets [3/8" Fittings]
HFX38-10	Pkg. of [10] Copper Flare Gaskets [3/8" Fittings]
HD1X14N-10	Pkg. of [10] Rubber Gaskets [1/2" & 5/8" Fittings]
HFX12-10	Pkg. of [10] Copper Flare Gaskets [1/2" Fittings]

5 HVAC/R TOOLS



Refrigerant Hoses



Super Black Magic[®]

FOR U.S. JOBS
UNIWELD EMPLOYS OVER 300 WORKERS

Uniweld's Super Black Magic[®] Refrigeration hoses for permanent installation are long lasting, trouble free alternatives to traditional copper capillary tubing used on refrigerant pressure and oil cutout controls. The wizardry of this hose is a seamless nylon tube wrapped with synthetic braid reinforcement and covered with black thermoplastic elastomer for maximum abrasion resistance. Refrigerant service technicians appreciate its easy installation in refrigeration rack systems in Supermarkets, Processing Plants and Paper Mills and its cost effectiveness. Available with optional 90° fittings.



Straight Rubber Gasket Seat



Specifications:

- Maximum Operating Pressure: 800 PSI (34 Bar)
- Burst Pressure: 4000 PSI (173 Bar)
- Maximum Working Temperature: 250°F (122°C)
- Minimum Bend Radius: 2" (50.8mm)



	Length	Straight x Straight Part#	Straight x 90° Part#	90° x 90° Part#	Description
1/4" F.F x 1/4" F.F. Super Black Magic[®] Hoses	12" 30cm	H012A400A	H012A409A	H012A410A	1/4" Female Flare x 1/4" Female Flare
	18" 45cm	H018A400A	H018A409A	H018A410A	1/4" Female Flare x 1/4" Female Flare
	24" 60cm	H024A400A	H024A409A	H024A410A	1/4" Female Flare x 1/4" Female Flare
	30" 75cm	H030A400A	H030A409A	H030A410A	1/4" Female Flare x 1/4" Female Flare
	36" 90cm	H036A400A	H036A409A	H036A410A	1/4" Female Flare x 1/4" Female Flare
	48" 120cm	H048A400A	H048A409A	H048A410A	1/4" Female Flare x 1/4" Female Flare
	60" 150cm	H060A400A	H060A409A	H060A410A	1/4" Female Flare x 1/4" Female Flare
3/8" F.F x 3/8" F.F. Super Black Magic[®] Hoses	12" 30cm	HD1A700A	HD1A709A	HD1A710A	3/8" Female Flare x 3/8" Female Flare
	18" 45cm	HD018A700A	HD018A709A	HD018A710A	3/8" Female Flare x 3/8" Female Flare
	24" 60cm	HD2A700A	HD2A709A	HD2A710A	3/8" Female Flare x 3/8" Female Flare
	30" 75cm	HD030A700A	HD030A709A	HD030A710A	3/8" Female Flare x 3/8" Female Flare
	36" 90cm	HD3A700A	HD3A709A	HD3A710A	3/8" Female Flare x 3/8" Female Flare
	48" 120cm	HD4A700A	HD4A709A	HD4A710A	3/8" Female Flare x 3/8" Female Flare
	60" 150cm	HD5A700A	HD5A709A	HD5A710A	3/8" Female Flare x 3/8" Female Flare

	Part#	UPC#	Description
Replacement Parts	HFX14-10	47608	Pkg. of [10] Copper Flare Gaskets [1/4" Hose]
	HFX38-10	47609	Pkg. of [10] Copper Flare Gaskets [3/8" Hose]

5 HVAC/R TOOLS



Uniweld Products, Inc. Fort Lauderdale, FL 33312 U.S.A. Customer Service: 800.323.2111
info@uniweld.com • www.uniweld.com

65



Adaptors/Fittings/O-Rings/Tool

Adaptors & Accessories

FOR U.S. JOBS
UNIWELD EMPLOYS OVER 300 WORKERS



**UNDER
PRESSURE**



92836
Refrigerant Drum Adaptor
3/4" NPS Cylinder x 1/4" M.F.

	Part #	Description
1/4"	EZAB	Straight 1/4" M.F. x 1/4" F.F.
	EZAB90	90° 1/4" M.F. x 1/4" F.F.
5/16"	EZABM	Straight 1/4" M.F. x 5/16" F.F.
	EZABM90	90° 1/4" M.F. x 5/16" F.F.
R-410A Mini Split		

EZHRK
Pkg. of (1) Spring
(1) Anti-Blowback Depressor
(1) Square Seat (2) O-Rings
and (1) Hose Gasket



92863
R-410A Mini-Split Adaptor
5/16" (1/2"-20) Female
w/Adjustable Depressor
x 1/4" Male w/Valve Core



92816
R-134a and R-12
Vacuum Pump Adaptor
1/4" F.F. x 1/2" ACME M. x 1/4" M.F.



92820
Valve Core Tool Double ended for
removing and installing both
standard and large bore
valve cores

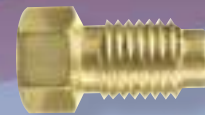

13401
1/4" F.F. x 1/2" ACME M.

Replacement Tethered Caps
92817 - 1/4" Plastic Cap (Pkg. 10)
92818 - 1/2" ACME Plastic Cap (Pkg. 10)

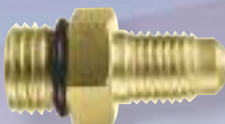

92800
14mm M. x 1/4" M.F.



92801
14mm M. x 3/8" M.F.

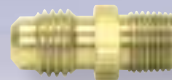

10005
1/4" M.F. x 1/8" M.P.T.



92799
1/2" ACME F. x 1/4" M.F.

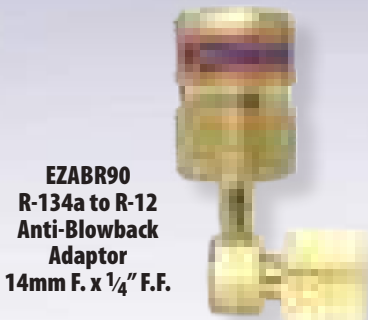

EZABR90
R-134a to R-12
Anti-Blowback
Adaptor
14mm F. x 1/4" F.F.



ABB134
Straight Anti-blowback Adaptor
1/2" ACME F. x 1/2" ACME M.



ABBRK
Anti-Blowback
O-Ring Repair Kit
(Pkg. of 4)
For ABB125, ABB190
ABB1425, ABB410

5 HVAC/R TOOLS





Propane Halide Leak Detector

Halide Leak Detector

FOR U.S. JOBS
UNIWELD EMPLOYS OVER 300 WORKERS

Uniweld's Propane Halide Leak Detector instantly locates non-combustible halide (CFC & HCFC) refrigerant gas leaks. Leaks are located when the chlorine based refrigerant gases are drawn in through the probe hose and exposed to a heated copper reactor plate, changing the blue flame to green. This detector is very sensitive and can be used to locate leaks as small as 20 ppm of CFC and HCFC refrigerants. **Will not detect non-chlorine based refrigerants (such as R-410A).**



Part# Description

PCLD33T	Propane Halide Leak Detector w/ Tool Box includes: PLD33V Leak Detector w/probe hose, FL34 Flint Lighter, PDC Propane Cylinder & Plastic Tool Box. [9 per case]
PCLD33	Propane Halide Leak Detector includes: PLD33V Leak Detector w/probe hose & PDC Propane cylinder. [6 per case]
PLD33	Propane Halide Leak Detector with probe hose, for air/fuel torch handle
PLD33V	Propane Halide Leak Detector with probe hose valve assembly
LD32	Halide Leak Detector for air/acetylene use
CC61	Plastic Tool Box (12.5" L x 7" W x 5" H)
H02-3	3ft. Probe Hose
PCV	Valve Assembly Only
LDPLC	Copper Reactor Plate
LD7-1A	Injector for LD-16 assembly



5 HVAC/R Tools



Uniweld Products, Inc. Fort Lauderdale, FL 33312 U.S.A. Customer Service: 800.323.2111
info@uniweld.com • www.uniweld.com

67

AUTOMOTIVE



R-134a/R-12 Automotive 2 Valve Brass Manifolds

Man, What a Manifold®

FOR U.S. JOBS
UNIWELD EMPLOYS OVER 300 WORKERS

COLOR CODED
GAUGE BOOTS



Lens
Plug
for easy
zero
reset

48800

Automatic Service Couplers

90045 High Side

90046 Low Side



Manual Service Couplers

90043 High Side

90044 Low Side

Uniweld's Automotive 2-Valve Brass Manifold has a solid forged brass body with metal hand wheels and a convenient hose holder. The large R-134a/R-12 gauges are protected with color-coded gauge boots. Options include manual or automatic Service Couplers, Soft Magic® Hoses and either 2½" LPF™ or 3⅛" NPF® Gauges.

	Hose Set Length	Soft Magic® Hoses Manual Couplers	Soft Magic® Hoses Auto Couplers		Hose Set Length	Soft Magic® Hoses Manual Couplers	Soft Magic® Hoses Auto Couplers
47827 Manifold 2½" LPF™ Gauges	36" [90cm]	47850	48050	48800 Manifold 3⅛" NPF® Gauges	36" [90cm]	48851	48801
	60" [150cm]	47851	48051		60" [150cm]	48852	48802
	72" [180cm]	47852	48052		72" [180cm]	48853	48803
	96" [240cm]	47853	48053		96" [240cm]	48854	48804

48075 Manifold with [2] 3 ft., [1] 5 ft. Soft Magic® hoses and automatic couplers.

48805 Manifold with [2] 3 ft., [1] 5 ft. Soft Magic® hoses and automatic couplers.

NOTE: R-12 service connections are not included.

6 Automotive A/C

68



Uniweld Products, Inc. Fort Lauderdale, FL 33312 U.S.A. Customer Service: 800.323.2111
info@uniweld.com • www.uniweld.com



R-134a/R-12 Automotive 2 Valve Aluminum Manifolds

Man, What a Manifold®

FOR U.S. JOBS
UNIWELD EMPLOYS OVER 300 WORKERS

**COLOR CODED
GAUGE BOOTS**

**NPF®
Silicone
Dampened
Movement**

**Lens
Plug
for easy
zero
reset**

**90044
Low Side**

**Manual
Service
Couplers**

91600

**90043
High Side**

Uniweld's R-134a Automotive anodized aircraft Aluminum Block Manifold features a large optical sight glass for monitoring refrigerant. High and low side brass valves provide precision control. Optional manual or automatic Service Couplers available with either 2½" LPF™ or 3⅛" NPF® gauge Manifolds.

	Hose Set Length	Soft Magic® Hoses Manual Couplers	Soft Magic® Hoses Auto Couplers		Hose Set Length	Soft Magic® Hoses Manual Couplers	Soft Magic® Hoses Auto Couplers
90000 Manifold 2½" LPF™ Gauges	36" [90cm]	90007	90750	91600 Manifold 3⅛" [80mm] NPF® Gauges	36" [90cm]	91651	91601
	60" [150cm]	90008	90751		60" [150cm]	91652	91602
	72" [180cm]	90009	90752		72" [180cm]	91653	91603
	96" [240cm]	90010	90753		96" [240cm]	91654	91604

NOTE: R-12 service connections are not included.



Uniweld Products, Inc. Fort Lauderdale, FL 33312 U.S.A. Customer Service: 800.323.2111
info@uniweld.com • www.uniweld.com



6 Automotive A/C



Soft Magic® Charging Hoses

Automotive Hoses

FOR U.S. JOBS
UNIWELD EMPLOYS OVER 300 WORKERS

Uniweld's Soft Magic® super-flexible hose for under the hood and tight work areas. The yellow charging hose includes an anti-blowback fitting. Meets SAE J2196/R-134a specifications.

1/2" ACME with Anti-blowback fittings

Specifications:

- Maximum Operating Pressure: 800 PSI (34 Bar)
- Burst Pressure: 4000 PSI (173 Bar)

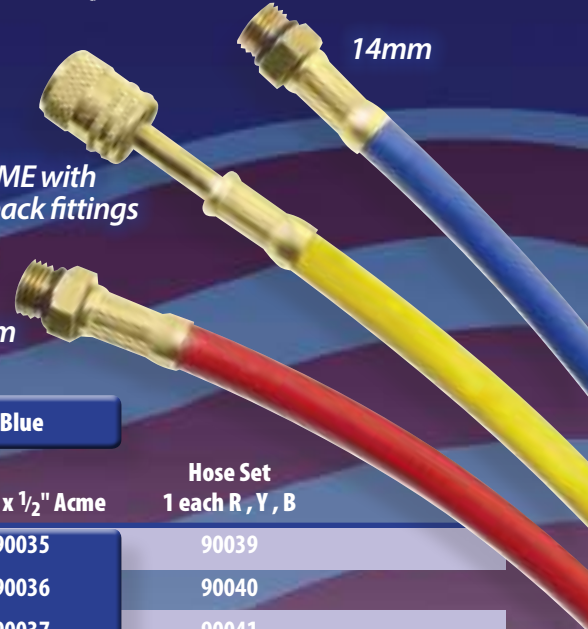

	Hose Length	Yellow 1/2" Acme x 1/2" Acme w/Anti-Blowback	Red 14mm x 1/2" Acme	Blue 14mm x 1/2" Acme	Hose Set 1 each R, Y, B
Black Magic®	36"	90027	90031	90035	90039
	60"	90028	90032	90036	90040
	72"	90029	90033	90037	90041
	96"	90030	90034	90038	90042
Soft Magic®	36"	49008	49000	49004	49020
	60"	49009	49001	49005	49021
	72"	49010	49002	49006	49022
	96"	49011	49003	49007	49023

	Part#	UPC#	Description
Replacement Parts	90059	90059	Package of [2] 14mm O-Rings and [4] 1/2" Acme Gaskets
	HR134N-10	13414	Package of 10 pieces. 1/2" Acme Gaskets
	HR134N-100	13415	Package of 100 pieces. 1/2" Acme Gaskets

Automotive Replacement Gauges

R-134a/R-12 - PSI°F with color coded gauge boots on large easy to read dials.



G10LAD
2 1/2" LPF™



G409NSAD
3 1/8" NPF®

Part#	Description
G9LAD	2 1/2" LPF™ 0-500 psi
G10LAD	2 1/2" LPF™ 30"-Hg-120 psi, 300 psi Overpressure
G409NSAD	3 1/8" NPF® 0-500 psi
G410NSAD	3 1/8" NPF® 30"-Hg-120 psi, 300 psi Overpressure

6 Automotive A/C

70



Uniweld Products, Inc. Fort Lauderdale, FL 33312 U.S.A. Customer Service: 800.323.2111
info@uniweld.com • www.uniweld.com



R-134a Manual Service Couplers with 8 balls

Service Couplers

FOR U.S. JOBS
UNIWELD EMPLOYS OVER 300 WORKERS

Uniweld's improved R-134a Manual Service Couplers accurately centers to the schrader valve. This prevents damage to the schrader and securely locks the coupler onto the A/C service port.

	Part#	Description		
Manual Service Couplers	90043	Manual Red-High Side [14mm Female]	 90043 High Side	
	90044	Manual Blue-Low Side [14mm Female]		 90044 Low Side
	90478	Manual Red-High Side w/92800 [1/4" M.F. Adaptor]		
	90479	Manual Blue-Low Side w/92800 [1/4" M.F. Adaptor]		
		90480	Manual Red-High Side w/92801 [3/8" M.F. Adaptor]	
		90481	Manual Blue-Low Side w/92801 [3/8" M.F. Adaptor]	
Automatic Service Couplers	90045	Automatic Red-High Side [14mm Female]	 90045 High Side	
	90046	Automatic Blue-Low Side [14mm Female]		 90046 Low Side
	90483	R-134a Automatic Coupler - Red/High w/92800 [1/4" M.F. Adaptor]		
	90484	R-134a Automatic Coupler - Blue/Low w/92800 [1/4" M.F. Adaptor]		
		90485	Automatic Service Coupler Kit: Red-High Side [14mm F.] & Blue-Low Side [14mm F.] Couplers	
		90486	Automatic Service Coupler/Adaptor Kit: Red-High Side [14mm F.] & Blue/Low Side [14mm F.] Couplers with two 92800 1/4" M.F. Adaptors	
Repair Kit	90482	Service Coupler O-Ring Repair Kit Includes: [1 each] X09R Low side and X11R High side		

R-134a and R-12 Conversion Kits

R-134a Automatic Service Couplers are designed for working in tight spaces. Push down on the coupler to snap it easily onto the A/C service port and automatically open the valve core.



	Part#	Description
R-134a and R-12 Conversion Kits	47881	R-134a to R-12 Conversion Kit: [2] ABB1425 & [1] 13401 Adaptor
	47880	R-12 to R-134a Conversion Kit: 90478, 90479 Manual Couplers and 92799 Adaptor 1/2" Acme F. X 1/4" M.F.



Uniweld Products, Inc. Fort Lauderdale, FL 33312 U.S.A. Customer Service: 800.323.2111
info@uniweld.com • www.uniweld.com

71

6 Automotive A/C

AUTOMOTIVE



A/C Flush Kit / Can Tap Valve / Recharge Hose

R-134a Auto Accessories

FOR U.S. JOBS
UNIWELD EMPLOYS OVER 300 WORKERS

The A/C Flush Kit is used to remove moisture, contaminants and acid from the evaporator and the condenser. It is designed to work with any A/C flush solvent that can be mixed with pressurized air. Add up to 18 oz. of solvent to the reusable canister and with the use of pressurized shop air, reverse flush the evaporator and condenser during retrofitting or replacement.

FEATURES:

- *Pressure Relief Valve that opens automatically at 180 to 190 psi, protecting the cylinder and equipment from overpressure*
- *Valve Assembly with a Liquid Dip Tube*
- *Ball Valve with 1/4 turn open/close • 24" flexible Service Hose • Blow Gun fitted with Rubber Tip Nozzle*



	Part#	Description
Flush Kit	94180	Auto A/C System Flush Kit
Flush Kit Replacement Parts	BG1FA	Blowgun with Auto Rubber Tip Nozzle
	H2P100D	24" Service Hose
	40049	Auto Rubber Tip Nozzle with 1/8" M.P.T. Fitting

NOTE: Residential & Commercial A/C Flush Kit also available. See page 51

R-134a Can Tap Valve and Auto Recharge Hose

Self-piercing R-134a Can Tap Valve with 1/2" ACME fittings and "T" handle valve for easy fingertip control. The R-134a Recharge Hose assembly includes: the Can Tap Valve with hose and low side Service Coupler for quick, easy service of an auto A/C system.



	Part#	Description
Can Tap Valve and Hose	49016	R-134a Auto Recharge Hose with Can Tap Valve
	90060	R-134a Can Tap Valve with 1/2" Acme Male Fittings

6 Automotive A/C

AUTOMOTIVE



Oil/Dye Injector and A/C Adaptor Kit

R-134a Auto Accessories

FOR U.S. JOBS
UNI WELD EMPLOYS OVER 300 WORKERS



The refillable Oil/Dye Injector has a 2 oz. capacity. The anodized aluminum body and end caps are fitted with O-ring seals. Attach the injector directly to the manifold low side hose connection and add oil/dye to the system. Available with optional 1/2" ACME fittings or 1/4" Flare fittings.



94170

Part#	Description
94170	Refillable Oil/Dye Injector with 1/2" Acme fittings
94175	Refillable Oil/Dye Injector with 1/4" Flare fittings

Oil Injector

Universal A/C Adaptor Kit

The Universal A/C Adaptor Kit box contains the most popular adaptors for servicing an A/C system, including a universal ball valve with interchangeable service connectors. Also included are replacement parts for R-123 and R-134a service hoses.



Universal Ball Valve with interchangeable Service Connectors



92830

**92830
Universal
Adaptor Kit
Parts
List**

Part#	Description
BV501FX	Universal Ball valve with 1/4" M.F.
92786	1/4" Service Connector, straight
92788	1/4" Service Connector, w/90° bend
92795	3/16" Service Connector, straight
92797	3/16" Service Connector, w/90° bend
HX14N-10	1/4" Hose Gasket [10 pcs.]
H76S-10	1/4" Hose Depressor [10 pc.]
X09R	R-134a Low side Coupler O-Ring [5 pcs.]
X11R	R-134a High side Coupler O-Ring [5 pcs.]
X15R	Hose-O-Ring 14mm male [5 pcs.]
X40R	Service Connector O-Ring [10 pcs.]
HR134N-10	1/2" Acme Hose Gasket [10 pcs.]

6 Automotive A/C



Uniweld Products, Inc. Fort Lauderdale, FL 33312 U.S.A. Customer Service: 800.323.2111
info@uniweld.com • www.uniweld.com

73



Sludge Sucker®/Blaster® Kit Sludge Sucker®

FOR U.S. JOBS
UNIWELD EMPLOYS OVER 300 WORKERS

Nitrogen is a dry inert gas with multiple uses in the HVAC/R industry: purging and pressure testing copper tubing, calibrating pressure controls, cleaning a condensate drain line, cleaning coils, inflating tires, unlogging a sink, operating impact tools and much more.

Uniweld does not recommend that CO₂ be used for purging or pressure testing an A/C&R system because it may form carbonic acid within the system, causing premature equipment failure. The Sludge Sucker® Kit options include a choice of high or low-pressure regulators for Nitrogen or CO₂ [with optional F36 adaptor] and various carrying stands depending on tank size. All Sludge Sucker® Kits include the handy Sludge Blaster® for quickly unlogging drain pipes.



40004



Blow off coils with Sludge Sucker® Blowgun



Purge and pressure test an A/C&R system



Clean out condensate drain lines with Sludge Blaster®

2. Use PVC fittings, if needed, to attach vinyl hose to drain line.

1. Locate condensate drain line. Sludge Sucker® vinyl hose fits inside a 3/4" PVC fitting.



3. Allow Nitrogen to flow through Sludge Sucker® fitting and then watch the sludge get sucked out of the drain line and blown onto the ground.

Part#	Regulators	Sludge Item	Hoses	Blowgun	Carrying Stand
40001	R1563 [Delv. 5-175 psi]	40000			515 [20 cu. ft.]*
40002	R1563 [Delv. 5-175 psi]	Sludge Sucker®	H5SMBY 5 ft. hose		516 [40/55 cu. ft.]*
40003	RHP500 [Delv. 20-500 psi]			BG1	515 [20 cu. ft.]*
40004	RHP500 [Delv. 20-500 psi]	40061	H2SSM 2 ft. hose		516 [40/55 cu. ft.]*
40039	RHP400 [Delv. 20-400 psi]	Sludge Blaster®			515 [20 cu. ft.]*
40040	RHP400 [Delv. 20-400 psi]				516 [40/55 cu. ft.]*

*Tank not included.





Sludge Sucker® Maintenance Kit

Sludge Sucker®

FOR U.S. JOBS
UNIWELD EMPLOYS OVER 300 WORKERS

A versatile, all-in-one kit that includes a Nitrogen regulator with a delivery pressure up to 400 PSI for pressure testing an A/C&R system for leaks. It also includes many accessories for cleaning condensate drain lines and for blowing off coils. It even has a air chuck to fill up that flat tire. As a bonus, our Sludge Blaster® is included (see page 80 for more information). Carry stands are sold separately (see page 41).



Blow off coils with Sludge Sucker® Blowgun



Clean condensate drain lines with the Sludge Blaster®



Inflate tire with the Sludge Sucker® Air Chuck

7 Nitrogen & CO₂



40055

40055 Sludge Sucker® Maintenance Kit

Part#	Description	Part#	Description
RHP400	Nitrogen Regulator	40048	Needle Tip
40000	Sludge Sucker®	40050	1/2" Rubber Plug
40061	Sludge Blaster®	40022	3/4" Rubber Plug
H2SSM	2 Ft. Hose	BG1	Blowgun
H5SMBY	5 Ft. Hose	40045	Air Chuck

40077 Sludge Blaster® Accessory Kit

Already own a Nitrogen regulator? Then this 8-piece accessory kit is for you. It attaches to your regulator and includes the most popular tools to unclog and flush drain lines.

Part#	Description	Part#	Description
40061	Sludge Blaster®	40050	1/2" Rubber Plug
H2SSM	2 Ft. Hose	40022	3/4" Rubber Plug
H5SMBY	5 Ft. Hose	BG1	Blowgun
40048	Needle Tip	40045	Air Chuck

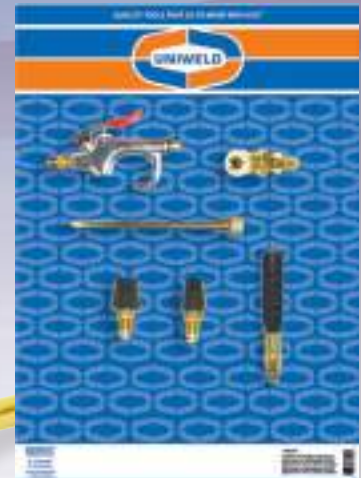

40077



Now with Twice the Suction Power



Sludge Sucker®

FOR U.S. JOBS
UNIWELD EMPLOYS OVER 300 WORKERS

The Sludge Sucker® is a tool that was developed to clean out a condensate drain line without accessing the drain pan located in the air handler. The Sludge Sucker's clear vinyl hose is attached to the 3/4" PVC condensate drain line on the outside of the building. With the use of Nitrogen or CO2, suction is created and that pulls all the sludge and algae from the drain pan and drain line; then blows it onto the ground outside.

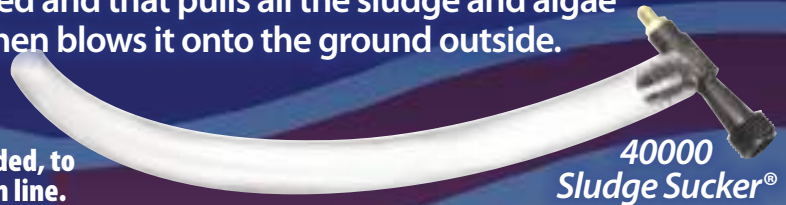

40000
Sludge Sucker®

2. Use PVC fittings, if needed, to attach vinyl hose to drain line.

1. Locate condensate drain line. Sludge Sucker® vinyl hose fits inside a 3/4" PVC fitting.



3. Allow Nitrogen to flow through Sludge Sucker® fitting and then watch the sludge get sucked out of the drain line and blown onto the ground.



40061
Sludge Blaster®

Part#	Description
40000	Sludge Sucker® with clear vinyl hose.

Sludge Blaster®/Drain Blaster®

1. Insert Sludge Blaster® into the "T" connection at the air handler.



3. Replace PVC cap on "T" connection For future service: DO NOT GLUE PERMANENTLY.

2. Allow Nitrogen (at max. 140 PSIG) to flow through, blasting the sludge free.

Unclog A/C condensate drain pipes FAST with Sludge Blaster®. It expands inside the pipe and with pressure exerted on the clog, blasts the sludge free. Attaches to standard 3/4" service hose. Pipe capacity: 3/4" to 1" I.D.



Unclog drain pipes FAST with Drain Blaster®. It expands inside the pipe and exerts water pressure on the clog...blasting it free. Attaches to standard 3/4" garden hose.

Part#	Description	Pipe Capacity
40061	Sludge Blaster®	3/4" to 1" I.D.
40062	Drain Blaster™	1" to 2" I.D.
40063	Drain Blaster™	1 1/2" to 3" I.D.
40064	Drain Blaster™	3" to 6" I.D.

Blowgun/Blowgun Accessories/Rubber Plugs



Accessories

FOR U.S. JOBS
UNIWELD EMPLOYS OVER 300 WORKERS



BG1 Blowgun for Sludge Sucker® Kit



40045 Air Chuck

Blowgun Accessories



H5SMY 5 Ft. Service Hose

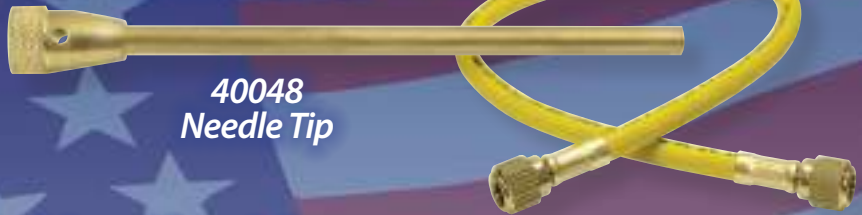

40048 Needle Tip

H2SSM 2 Ft. Service Hose

Rubber Plug Adaptors

Rubber Plug Adaptors are primarily used for drainline flushing.



Flush out a clogged sink drain using Rubber Plug Adaptors.

Part#	Description
40045	Air Chuck with 1/4" M. F. fitting
40048	Needle Tip [attaches to blowgun]
BG1	Blowgun with safety tip 1/4" M. F. inlet & outlet [Maximum working pressure: 120 psi]
H2SSM	2 Ft. Service Hose [attaches to blowgun]
H5SMY	5 Ft. Service Hose [attaches to blowgun]
40050	Rubber Plug Adaptor* [1/2" x 3/4" Cone]

Part#	Description
40051	Rubber Plug Adaptor* [1" x 1 1/4" Cone]
40052	Rubber Plug Adaptor* [1 1/4" x 1 1/2" Cone]
40053	Rubber Plug Adaptor* [1 1/2" x 2" Cone]
40054	Rubber Plug Adaptor* [2" x 2 1/2" Cone]
40022	Rubber Plug Adaptor* [3/4" x 7/8" Cone]

*with 1/4" M.F. fittings.



Uniweld Products, Inc. Fort Lauderdale, FL 33312 U.S.A. Customer Service: 800.323.2111
info@uniweld.com • www.uniweld.com



7 Nitrogen & CO2

Nitrogen Flow Indicator/Regulators



Nitrogen Flow

FOR U.S. JOBS
UNIWELED EMPLOYS OVER 300 WORKERS

NV1 NitroVue is nitrogen purging simplified. The easy to read flow indicator label and the precision adjustable valve give complete control over the low flow of nitrogen gas during the brazing of copper tubing in Air Conditioning and Refrigeration systems. The bright orange float ball visually confirms the flow of nitrogen gas and allows the technician to first "PURGE" the copper lines at 20+ SCFH and then reduce the flow to "BRAZE" at 3-5 SCFH during the brazing process thus conserving its consumption and reducing operating cost.

The nitrogen must be flowing to displace the oxygen inside the tubing during the brazing process, preventing internal oxidation and the resulting scale. Scale build up inside the tubing can cause blockage in the TXV and within the Air Conditioning and Refrigeration system resulting in premature failure. If the orange ball does not rise in the tube there is no flow of nitrogen, only static pressure and oxygen is not being displaced. The NV1 must be connected to a Nitrogen Regulator with the delivery pressure set at 60 PSI to control the nitrogen gas pressure. The NV1 can be used with complete confidence because it is protected from over pressure with a resealable safety blow off that opens at 200+ PSI.

Patent Pending

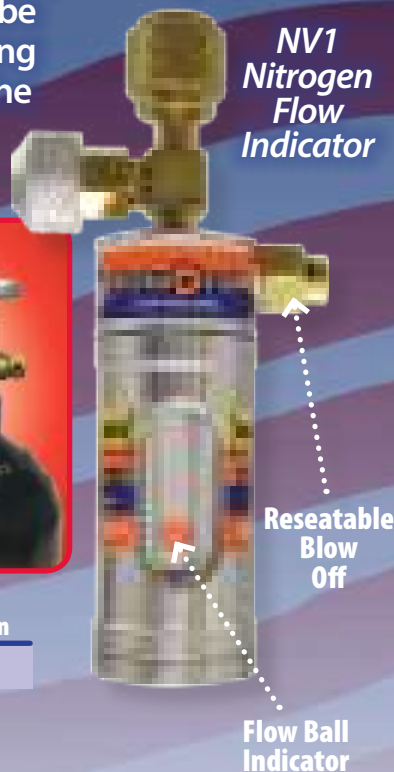

Part#	UPC#	CGA Inlet	Outlet Connection
NV1	14040	1/4" F.F.	1/4" M.F.

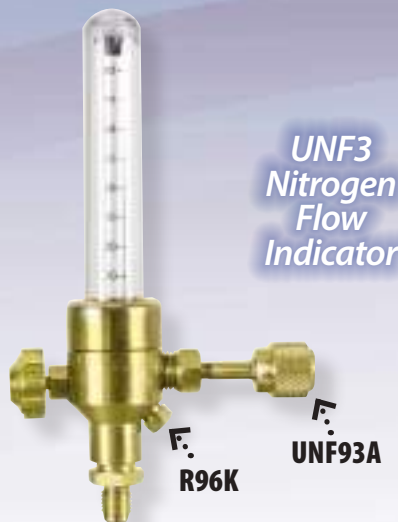

UNF3
Nitrogen
Flow
Indicator



Maximum Inlet Pressure: 50 PSI

Flow Ball Indicator

Part#	UPC#	CGA Inlet	Outlet Connection
UNF3	14030	1/4" F.F.	1/4" M.F.

Part# Replacement Parts

R96K	12026	Pressure Relief Kit: Includes (1) copper disk, (2) washers and (1) brass relief cap
UNF93A	14032	Inlet Assembly

Regulators/Replacement Gauges



Nitrogen/CO₂ Regulators

FOR U.S. JOBS
UNIWELD EMPLOYS OVER 300 WORKERS

Regulators for use with Nitrogen or CO₂ (with optional F36 adaptor) that have been specially designed for purging and pressure testing. Large "T" handle with stainless steel pressure adjusting screw and bushing prevent galling.

7 Nitrogen & CO₂



F36 Adaptor
CO₂ Cylinder
(CGA320) to
Nitrogen (CGA580)

Part#	UPC#	CGA Inlet	Outlet Connection	Gauges Delivery/Contents	Delivery PSIG
RHP400	13000	580	1/4" M.F.	[G8SD] 600/4000 [G7SD]	0-400
RHP500	13100	580	1/4" M.F.	[G8SD] 600/4000 [G7SD]	0-500
RHP800	13800	580	1/4" M.F.	[G34SD] 1000/4000 [G7SD]	0-800

Part#	Pressure	Diam.	Case	N.P.T.
G34SD	1000 psi	2"	Gold Steel Case	1/4"
G7SD	4000 psi	2"	Gold Steel Case	1/4"
G8SD	600 psi	2"	Gold Steel Case	1/4"

NOTE: REPLACEMENT GAUGES DO NOT INCLUDE 2" GAUGE BOOT [SOLD SEPARATELY]



GB205
2" Gauge Boot Set (2) Black

Nitrogen and CO₂ Regulators

A compact, proven design for soft drink dispensing systems (not beer) and for many types of pressurizing applications. Features include: an adjustable pressure screw with locking nut and a self re-seating relief valve (not designed to protect downstream systems).

	CO ₂ Part#	Nitrogen Part#	1 1/2" Gauges/Delivery	Delivery PSIG
Single Gauge Regulator	R1346	R1546	60 [G83D]	2-50
	R1349	R1549	300 [G84D]	2-175
	CO ₂ Part#	Nitrogen Part#	Nitrogen/CO ₂ Delivery/Contents	Delivery PSIG
Dual Gauge Regulator	R1358	R1558	[G20D] 15/4000 [G82D]	2-12
	*R1360	*R1560	[G83D] 60/4000 [G82D]	2-50
	*R1362	*R1562	[G78D] 200/4000 [G82D]	5-120
	*R1363	*R1563	[G84D] 300/4000 [G82D]	5-175



R1563

- CGA320-CO₂ inlet connection with O-ring
- CGA580-Nitrogen inlet connection
- 1/4" SAE flare outlet
- U.L. Listed

*Gauges shipped with protective boots



Uniweld Products, Inc. Fort Lauderdale, FL 33312 U.S.A. Customer Service: 800.323.2111
info@uniweld.com • www.uniweld.com

79

Ratchet-action Cutters for plastic pipe



PVC Pipe Cutters

FOR U.S. JOBS
UNIWELD EMPLOYS OVER 300 WORKERS

The ideal cutting tools for plastic pipe commonly used for condensate drain line, plumbing lines, irrigation and electrical conduit. Easy-to-use ratchet-action mechanism and hardened steel blade replaces that old saw blade that never cut clean or straight. The blade holds a sharp edge and is easily field replaceable. Cuts cleanly through all plastic pipe including: PVC, CPVC and Polyethylene.

8 Tubing Tools



1 Release safety lock and pull handles open with both hands.



2 Position pipe in the cutter and close handles together to engage ratchet. Blade begins to cut on contact.



3 Close and release handles using ratcheting action to cut through the pipe.



4 Use inside/outside Deburring Tool (Uniweld #70079) to remove burrs from pipe.

70087
PVC Ratchet
Pipe Cutter
Cuts up to
2½" O.D. (63mm)



70080
Replacement
Blade

70121
Replacement
Spring



70078
PVC Ratchet Pipe
Cutter cuts up to
1½" O.D. (42mm)



20'N'1 and 6'N'1 Screwdrivers



Ratchet Screwdrivers

FOR U.S. JOBS
UNIWELD EMPLOYS OVER 300 WORKERS

20 'N' 1 Ratchet Screwdriver

Multi-tip Ratchet Screwdriver with 14 magnetic interchangeable double-end bits, three nut drivers, two valve core extractors and one wire bender.

3 Ratchet Driver settings: Forward/Reverse/Manual



1/4" Nut Driver



5/16" Nut Driver

20N1RSD

12 Bit Storage Area



7/16" Nut Driver



Wire Bender
(up to 12 ga.)



Valve Core
Removal Tool



Valve Core
Pick Extractor

Display
Package

3/16" Slotted

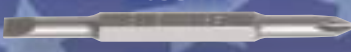

RSDBIT1



#1 Phillips

T-10 Torx

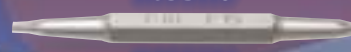

RSDBIT5



T-15 Torx

1/4" Slotted

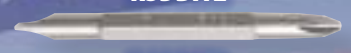

RSDBIT2



#2 Phillips

5/32" Allen



RSDBIT6



1/8" Allen

5/16" Slotted



RSDBIT3



#3 Phillips

1/4" Allen

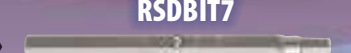

RSDBIT7



3/16" Allen

S-1 Square



RSDBIT4



S-2 Square

Valve Core
Pick
Extractor



RSDBIT8



Valve Core
Removal
Tool

6 'N' 1 Ratchet Screwdriver

Change bits and driver sizes quickly with a pull, flip and click. Work with 4 magnetized bits and 2 driver sizes. Three ratchet driver settings: Forward, Reverse & Manual.



6N1RSD

#1 Phillips

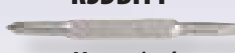

RSDBIT1

Magnetized



3/16" Slotted

3 Ratchet Driver settings:
Forward/Reverse/Manual

#2 Phillips



RSDBIT2

Magnetized



1/4" Slotted

1/4" Nut Driver



5/16" Nut Driver



Uniweld Products, Inc. Fort Lauderdale, FL 33312 U.S.A. Customer Service: 800.323.2111
info@uniweld.com • www.uniweld.com

81

8 Tubing Tools

Reversible and Offset Wrenches/Dual Hex Wrench Adaptor



Ratchet Wrenches+

FOR U.S. JOBS
UNIWELD EMPLOYS OVER 300 WORKERS

Reversible & Offset Ratchet Wrenches

Double-end Reversible Ratchet Wrenches with offset design for knuckle clearance in tight work areas. Chrome plated, heat-treated alloy steel, strong gear teeth and easy-flip reversing mechanism. Packed with FREE! Dual Hex Wrench Adaptor.

70075
Heavy Duty
Offset Ratchet Wrench+
DHW316 Hex Adaptor
Hex openings:
1/2" and 9/16"
at one end;
Square openings:
1/4" and 3/16"
at other end



70075



For compressor
access valves and
Acetylene B & MC
tank valves



70074



70074
Medium Duty
Offset Ratchet Wrench+
DHW316 Hex Adaptor
Square openings:
1/4" and 3/16"
at one end;
5/16" and 3/8"
at other end

Dual Hex Wrench Adaptor

Dual Hex Wrench Adaptor for use on 3/16" and 5/16" hex liquid and suction valves on residential and commercial equipment. Fits Uniweld 70022 Reversible Ratchet Wrench, 1/4" square socket. Heat treat alloy steel, plated to prevent rust.



DHW316



Reversible Ratchet Wrench

Use for compressor access valves and Acetylene B & MC tank valves. Square opening: 1/4" and 3/16" at one end; 3/8" and 5/16" at other end.



70022

7 Tubing Tools

Inside / Outside Deburrers, Pinch-Off Tool



Deburring Tools

FOR U.S. JOBS
UNIWELD EMPLOYS OVER 300 WORKERS

The 70072 Inside/Outside Deburring Tool quickly removes burrs and sharp edges on all size tubing. A removable end cap exposes a convenient storage area for replacement blades.



70072

Used for deburring metal or PVC tubing ends, inside and out after cutting



The 70079 Inside/Outside Deburring Tool removes burrs and sharp edges with double edge steel blades. This heavy duty metal deburrer has a capacity of $\frac{1}{8}$ " to $1\frac{5}{8}$ " O.D. (3mm to 42mm).

Used for deburring metal or PVC tubing ends, inside and out after cutting



70079

Pinch-Off Tool

An effective way to isolate a piece of equipment in need of repair is to close off the tubing with the use of a Pinch-Off Tool. This works well in emergency situations that require immediate stopping of a leak. The maximum throat depth of this Pinch-Off Tool 70076 is 1" (25.4mm).



70076



Heavy Duty Flare/Burnish Tools



Flaring Tools

FOR U.S. JOBS
UNIWELD EMPLOYS OVER 300 WORKERS

The 70003 Heavy Duty Flaring Tool has a hardened steel flaring cone with a chrome finish for more uniform flares without galling. Special shaped wing nuts allow the long handle of the self-

centering yoke to be used as a lever when tightening. The hardened steel flaring bar grips tubing without scoring.

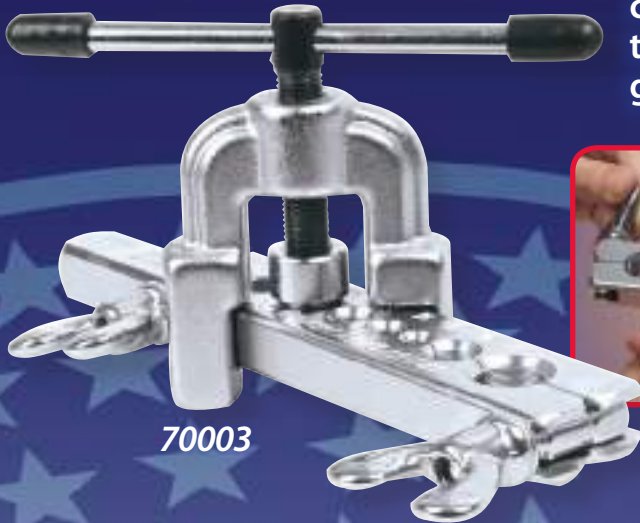

70003



For 45° flaring of 3/16", 1/4", 5/16", 3/8", 7/16", 1/2" and 5/8" O.D. soft copper, aluminum and brass tubing.

The 70004 Heavy Duty Flare/Burnish Tool has a specially designed hard chrome finish burnishing cone that automatically burnishes the flare face. The heat treated dies grip the tubing without scoring. The swivel-type yoke is self-centering.



70004

For 45° flaring of 3/16", 1/4", 5/16", 3/8", 1/2" and 5/8" O.D. soft copper, aluminum and brass tubing.



70071

The 70071 Deluxe Flaring Tool incorporates nine different sized hardened dies that rotate into position for the correct desired tube size. The compact design features a unique burnishing cone that achieves a smooth, polished flare. Heat treated dies grip the tubing without scoring or constricting.

Automatic tube height gauge shown at right.

For 45° flaring of 3/16", 1/4", 5/16", 3/8", 7/16", 1/2", 5/8", and 3/4" O.D. soft copper, aluminum and brass tubing.





Flare/Burnish/Swage Kit and Punch Type Swage Tool

Flaring/Swaging Tools

FORT U.S. JOBS
UNIWELD EMPLOYS OVER 300 WORKERS

Flare/Burnish and Swaging Tool Kit



70007

Swaging means one solder joint, not two. It now takes half the time to solder and braze the fitting with less chance of a leak.

For 45° flaring of 1/8", 3/16", 1/4", 5/16", 3/8", 7/16", 1/2", 5/8" and 3/4" O.D. soft copper, aluminum and brass tubing.



Part#	Description	Part#	Description
70048	3/16", 1/4", 3/8" O.D. Tube	70051	5/8" O.D. Tube
70049	5/16" O.D. Tube	70052	3/4" O.D. Tube
70050	1/2" O.D. Tube	70053	45° Flare

Converts quickly to Swaging Tool with use of Swage Adaptors for 3/16", 1/4", 5/16", 3/8", 7/16", 1/2", 5/8" and 3/4" O.D. tubing. Kit with swivel-type self centering yoke fitted in plastic case with instructions.

Punch Type Swaging Tools

Designed to enlarge one end of copper tubing to make a connection without a fitting. Swaging means one solder joint, not two. It now takes half the time to solder and braze the fitting with less chance of a leak.



70006

Part#	Description
70006	Multi Swage Punch [6-in-1] 3/16", 1/4", 5/16", 3/8", 1/2", 5/8" O.D.



70005

Part#	Description
70005	Swage Punch Kit- 5 pcs. in Vinyl Pouch 1/4", 5/16", 3/8", 1/2", 5/8" O.D.



70046



70047

Part#	Description
70041	Swage Punch 1/4" O.D.
70042	Swage Punch 5/16" O.D.
70043	Swage Punch 3/8" O.D.
70044	Swage Punch 1/2" O.D.
70045	Swage Punch 5/8" O.D.
70046	Swage Punch 3/4" O.D.
70047	Swage Punch 7/8" O.D.

8 Tubing Tools





All New! Premium, Heavy Duty Tubing Cutters

FOR U.S. JOBS
UNIWELD EMPLOYS OVER 300 WORKERS

Premium Mini Cutters

UTC701



The Mini Cutter rollers are grooved to allow close cutting at flared end of tubing.



Part#	Capacity	Application
UTC701	1/8" to 1" O.D.	For Copper, Brass and Aluminum Tubing

**UTC701
MINI
TUBING
CUTTER**

FEATURES: • RUGGED CAST ALUMINUM BODY • COMPACT SIZE TO CUT IN TIGHT SPACES
• LARGE, NON-SLIP THUMBSCREW FOR PRECISE CUTTING PRESSURE CONTROL

8 Tubing Tools

UTC702



The sliding block design lets you cut in tight work areas.



Part#	Capacity	Application
UTC702	1/8" to 1 1/8" O.D.	For Copper, Brass and Aluminum Tubing

**UTC702
MINI
TUBING
CUTTER**

FEATURES: • RUGGED CAST ALUMINUM BODY • COMPACT SIZE TO CUT IN TIGHT SPACES
• LARGE, NON-SLIP THUMBSCREW FOR PRECISE CUTTING PRESSURE CONTROL

Premium Cutter

Handy fold-away reamer and bonus spare cutter wheel.



UTC703

Part#	Capacity	Application
UTC703	1/8" to 1 3/8" O.D.	For Copper, Brass and Aluminum Tubing

**UTC703
PREMIUM
TUBING
CUTTER**

FEATURES: • ENCLOSED TELESCOPIC FEED SCREW MECHANISM FOR SMOOTH CUTTING ACTION
• 4 ROLLER TRACKING FOR TRUE SQUARED CUT • FLARE CUT-OFF GROOVE FOR CLOSE CUTTING DAMAGED FLARE • FOLD-AWAY REAMER • SPARE CUTTER WHEEL



All New! Premium Heavy Duty/Quick-Action



Tubing Cutter

FOR U.S. JOBS
UNIWELD EMPLOYS OVER 300 WORKERS



Premium Cutter

UTC704

Use the built-in deburrer for smooth, tight fitting cut edges

Part#	Capacity	Application
UTC704	1/8" to 1 3/4" O.D.	For Copper, Brass and Aluminum Tubing

**UTC704
PREMIUM
TUBING
CUTTER**

FEATURES: • ENCLOSED TELESCOPIC FEED SCREW MECHANISM FOR SMOOTH CUTTING ACTION
• 4 ROLLER TRACKING FOR TRUE SQUARED CUT • FLARE CUT-OFF GROOVE FOR CLOSE CUTTING DAMAGED FLARE • BUILT IN DEBURRING TOOL • SPARE CUTTER WHEEL

Quick-Action Premium Cutter

The spring loaded ratchet cutter wheel feeding system enables quick-action contact/release for tubing size adjustment. Two small and two large rollers ensure true square cut on the smallest and the largest tubing capacities. For cutting brass, aluminum and copper tubing.



UTC705

Quick-action, spring loaded mechanism adjusts and releases for tubing size changes.

Part#	Capacity	Application
UTC705	1/4" to 2 3/4" O.D.	For Copper, Brass and Aluminum Tubing

**UTC705
PREMIUM
TUBING
CUTTER**

FEATURES: • 4 ROLLER TRACKING FOR TRUE SQUARE CUT • REMOVABLE DEBURRER
• SPARE CUTTER WHEEL

Part#	Description
UTC706	• 2 Cutter Wheels • Holder Axle • C-clip

**REPLACEMENT
PARTS**

Replacement Parts for: UTC701, UTC702, UTC703, UTC704, UTC705

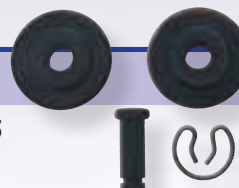

Uniweld Products, Inc. Fort Lauderdale, FL 33312 U.S.A. Customer Service: 800.323.2111
info@uniweld.com • www.uniweld.com

87

8 Tubing Tools



Standard and Mini Tubing Cutters

Tubing Cutters

FOR U.S. JOBS
UNIWELD EMPLOYS OVER 300 WORKERS

Precision feed screw mechanism that is enclosed to eliminate clogging and jamming for trouble-free performance. These tube cutters maintain the same length for accurate cutting of copper, brass and aluminum tubing in restricted spaces. The rollers are grooved for cutting close to flared end of tubing. A deburrer/reamer and spare cutter wheel are included.

70090



5/16" to 1 5/8" O.D.
(8mm to 42mm)

70090 includes a removable deburring tool for removing sharp edges from tubing. (Replacement #70091)



8 Tubing Tools



70001 includes a fold-away reamer tool for removing sharp edges from tubing.



1/8" to 1 1/4" O.D.
(3mm to 32mm)



70001

Mini Tubing Cutters

Compact body and sliding block design for use in restricted areas. The large, knurled feed screw knob provides precision adjustments. The rollers are grooved for cutting close to flared end of tubing. For copper, brass and aluminum tubing.



70000
1/8" to 7/8" O.D.
(3mm to 22mm)



70024
1/4" to 1 1/8" O.D.
(6mm to 28mm)
Spare Cutter Wheel





Quick Action Tubing Cutter

Tubing Cutter

FOR U.S. JOBS
UNIWELD EMPLOYS OVER 300 WORKERS

The spring loaded ratchet cutter wheel feeding system enables quick-action contact/release for tubing size adjustment. Two small and two large rollers ensure perfect cutting action on the smallest and the largest tubing capacities. For cutting brass, aluminum and copper tubing.

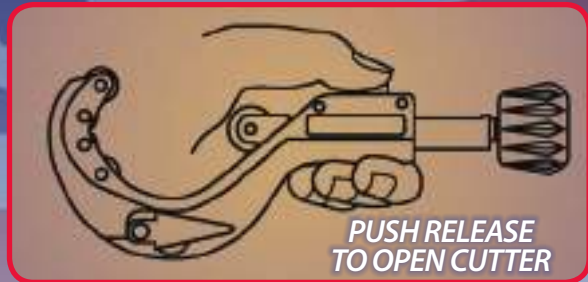
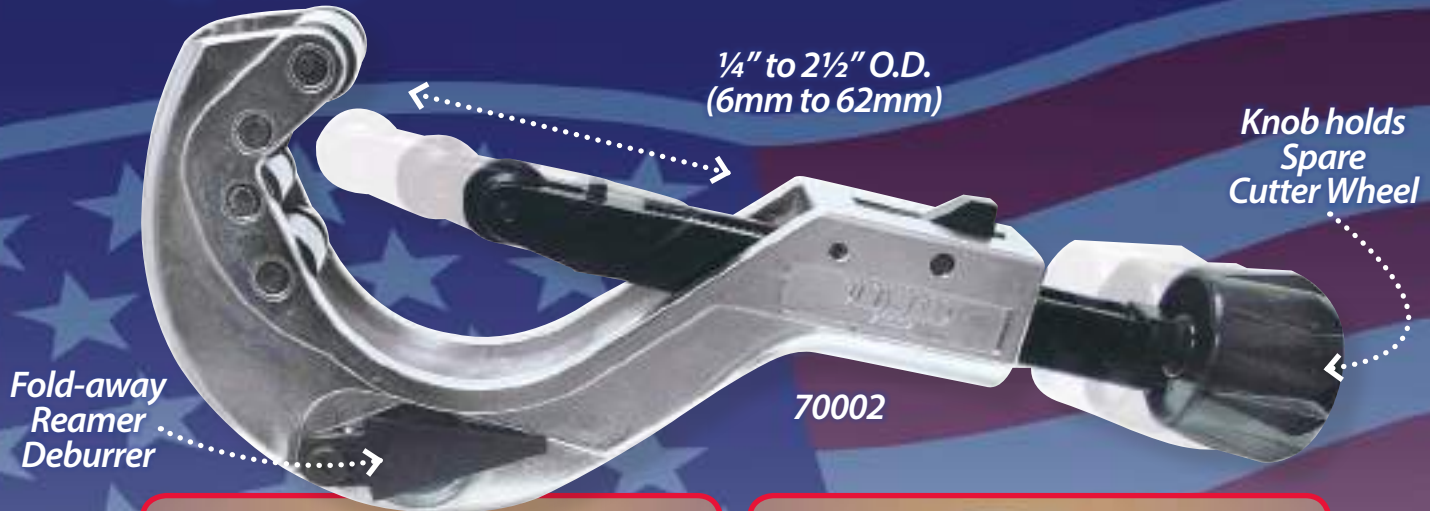

8 Tubing Tools

	Tubing Cutter	Cutter Wheel Display Pkg.	Cutter Wheel Bulk Pkg.	Cutter Wheel Screw
Tubing Cutter Replacement Parts	70000	70025	70029	70032
	70001	70025	70029	70032
	70002	70027	70031	70035
	70024	70025	70029	*[A] 70038 **[B] 70039
	70090	70027	70031	70035

*[A] Holder Axle, **[B] Clip



70040
Tubing Cutter Parts Kit
Includes: 6 each: 70031, 70035, 70038, 70039
12 each: 70029, 70032



Uniweld Products, Inc. Fort Lauderdale, FL 33312 U.S.A. Customer Service: 800.323.2111
info@uniweld.com • www.uniweld.com

CrossBow™ Tube Bender/Spring Benders



Ratchet Tube Bender

FOR U.S. JOBS
UNIWELD EMPLOYS OVER 300 WORKERS

UniWeld's CrossBow™ Ratchet Tube Bender enables plumbers and HVAC/R technicians to make precision bends up to 90° with soft copper and aluminum tubing. The low friction mandrels and rotating side support blocks provide precision bending in restricted spaces. Bend tubing sizes: 3/8", 1/2", 5/8", 3/4", 7/8", 1 1/8" O.D. You can produce bends with minimum distortion for optimal flow. Repeated alternate angled bends are possible with the CrossBow™ Ratchet Tube Bender, housed in a rugged plastic carrying case.

8 Tubing Tools



*CrossBow Kit includes:
6 interchangeable
mandrels; 3 rotating
side support block bars;
1 ratchet bender;
plastic carrying case
and instructions*



RTB118

Part#	Description
RTB118	Crossbow Ratchet Tube Bender, Sizes: 3/8", 1/2", 5/8", 3/4", 7/8", 1 1/8" O.D.
RTBCA118	1 1/8" Crossbar Assembly
RTBCA58	3/8", 1/2" and 5/8" Crossbar Assembly
RTBCA78	3/4" and 7/8" Crossbar Assembly
RTBM118	1 1/8" Mandrel for Crossbow Ratchet Tube Bender
RTBM12	1/2" Mandrel for Crossbow Ratchet Tube Bender
RTBM34	3/4" Mandrel for Crossbow Ratchet Tube Bender
RTBM38	5/8" Mandrel for Crossbow Ratchet Tube Bender
RTBM58	3/8" Mandrel for Crossbow Ratchet Tube Bender
RTBM78	7/8" Mandrel for Crossbow Ratchet Tube Bender
RTBR	Crossbow Ratchet Tube Bender Body Assembly
RTBRC	Crossbow Ratchet Tube Bender Replacement Case



*Minimum
distortion
bends up
to 90°*



Spring Tube Benders

Free-form bending of soft copper and aluminum tubing with UniWeld Spring Tube Benders. Spring slips over tubing and prevents collapsing of tube walls during bending. Achieve fast and professional bends.

70028
Spring Bender
Set

Part#	Description
70028	Bending Spring Set [4 Sizes] 1/4", 3/8", 1/2", 5/8" O.D.
70016	Bending Spring 1/4" O.D. [0.64 cm]
70017	Bending Spring 5/16" O.D. [0.79 cm]
70018	Bending Spring 3/8" O.D. [0.95 cm]
70019	Bending Spring 1/2" O.D. [1.27 cm]
70020	Bending Spring 5/8" O.D. [1.59 cm]
70021	Bending Spring 3/4" O.D. [1.90 cm]

90



UniWeld Products, Inc. Fort Lauderdale, FL 33312 U.S.A. Customer Service: 800.323.2111
info@uniweld.com • www.uniweld.com



3-in-1 Triple Tube Bender/Lever Benders

Tubing Benders

FOR U.S. JOBS
UNIWELD EMPLOYS OVER 300 WORKERS

The Uniweld 3-in-1 Triple Tube Bender is a compact and durable tool with multiple bending channels that is capable of bending 1/4", 5/16" and 3/8" O.D. soft copper, aluminum and soft stainless steel tubing. Calibrated markings show angle of bend for accurate left hand, right hand and offset bends up to 180°. 1" bend radius.

3-in-1 Triple Tube Bender



70010

70015

Lever Type Tube Benders



70014

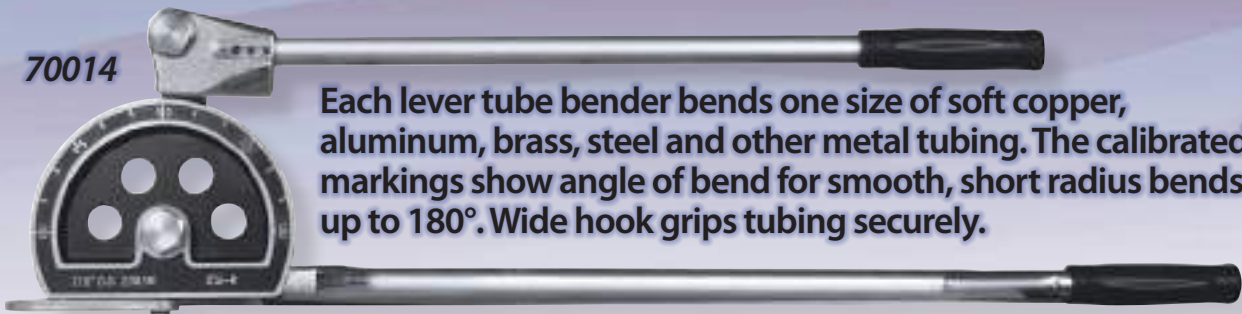

Each lever tube bender bends one size of soft copper, aluminum, brass, steel and other metal tubing. The calibrated markings show angle of bend for smooth, short radius bends up to 180°. Wide hook grips tubing securely.

Part#	Description	Tube Diam.	Bend Radius	Part#	Description	Tube Diam.	Bend Radius	Part#	Replacement Part
70009	Bender	5/16" O.D.	1 1/16"	70012	Bender	5/8" O.D.	2 1/4"	70082	Hook for 70012 Bender
70010	Bender	3/8" O.D.	1"	70013	Bender	3/4" O.D.	3"	70083	Hook for 70013 Bender
70011	Bender	1/2" O.D.	1 1/2"	70014	Bender	7/8" O.D.	3 1/4"	70084	Hook for 70014 Bender
								70085	Washer for 70086
								70086	Screw for 70082, 70083 & 70084

8 Tubing Tools



Uniweld Products, Inc. Fort Lauderdale, FL 33312 U.S.A. Customer Service: 800.323.2111
info@uniweld.com • www.uniweld.com

91



Gas Pressure Test Kit/Water Manometer

Check your Pressure

FOR U.S. JOBS
UNIWELD EMPLOYS OVER 300 WORKERS

This precision test kit includes a sensitive diaphragm gauge that is calibrated in inches of water column for extreme accuracy. Convenient to use without the mess of water or worry of mercury. Uniweld developed the 0-15" W.C. Gas Test Kit to accurately accommodate both natural gas at 3-4" W.C. and LP gas at 11-12" W.C.; eliminating the need for two separate kits.

Use these accurate kits to measure gas pressure across appliance manifolds. Test gas stoves, furnaces, dryers and other gas appliances.



A new Uniweld design feature allows you to easily zero reset the gauge needle by simply twisting open the dial lens to access the adjusting screw located on the dial face.



45503
Gas Pressure
Test Kit

Part#	Description
45503	Scale: 0-35" W.C., 0-20 oz./In ²
45506	Scale: 0-15" W.C., 8.6 oz./In ²

Part#	Description	Replacement Parts	Part#	Description
45595	Brass Fitting, Barbed x 1/8" M.P.T.		45598	Gauge Lens
45596	Rubber Nipple		45599	Carrying Case
45597	Black Rubber Hose			

Uniweld Gas Pressure Test Kits include: A Diaphragm Gauge that accurately sets manifold pressure for Natural or LP gas; a Brass Fitting (barbed x 1/8" M.P.T.) and rubber tube with nipple for easy connection; Molded Plastic Case; Instructions.

Water Manometer

An economical way to check/set manifold pressure in furnaces and gas appliances that use Natural or LP gas. Fill with water to zero and place in vertical position using the included magnet. Attach fitting to manifold and begin pressure test. Pressure reading (from 0-15" water column) is shown in small tube.

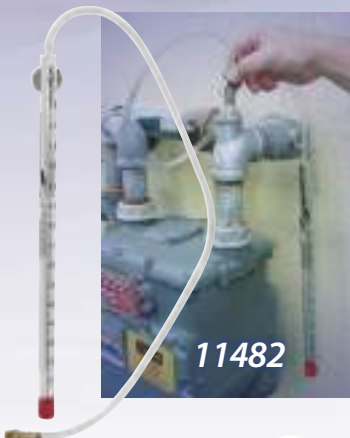

11482

9 Gauges



Bottom Mount/Center Back Mount/Lower Back Mount



Tridicators

FOR U.S. JOBS
UNIWELD EMPLOYS OVER 300 WORKERS

Designed primarily for hot water boiler systems. Two instruments in one...you can measure water pressure in PSI and H₂O feet, plus monitor temperature in °F and °C.

3 1/2" Tridicator has adjustable lens with indicator mark.

Round Tridicator Gauges

Large 2 1/2" and 3 1/2" round dials available in bottom and center back mount.



GT568
Bottom Mount



GT565
Center Back Mount x 2" Extension



GT512-2
Bottom Mount

3 1/2" Square Tridicator Gauges

Large 3 1/2" square dials available in bottom mount and lower back mount.



GT562-2
Lower Back Mount

Part#	UPC#	Description
GT512-2	69116	3 1/2" Square Tridicator, 0-60 PSI, 0-400 kPa and 70-250 °F, 20-120 °C, 1/2" NPT B.M.
GT562-2	69117	3 1/2" Square Tridicator, 0-60 PSI, 0-400 kPa and 70-250 °F, 20-120 °C, 1/2" NPT L.B.M.
GT565	69130	2 1/2" Round Tridicator, 0-75 PSI/170 ft. H ₂ O, 60-260 °F/20-120 °C, 1/4" NPT C.B.M. x 2" Extension
GT566	69131	2 1/2" Round Tridicator, 0-75 PSI/170 ft. H ₂ O, 60-260 °F/20-120 °C, 1/4" NPT C.B.M.
GT568	69133	3 1/2" [80mm] Round Tridicator, 0-75 PSI/170 ft. H ₂ O, 60-260 °F/20-120 °C, 1/2" NPT B.M.

Pocket Bi-Metal Thermometer

Pocket Thermometer with 1" dial and stainless steel case. Color-coded °F and °C dial face. Stainless steel 5" pointed stem. Field calibration.

69901
-40°F to 160°F
-40°C to 70°C



69902
-0°F to 220°F
-10°C to 104°C



Protective sheath with pocket clip



Uniweild Products, Inc. Fort Lauderdale, FL 33312 U.S.A. Customer Service: 800.323.2111
info@uniweild.com • www.uniweild.com

93

9 Gauges

Top Mount and Side Mount Gauges/Water Test Gauges



Gas Test Gauges

FOR U.S. JOBS
UNIWELD EMPLOYS OVER 300 WORKERS

Use to pressure test all new installations for leaks and inspection codes. After installation and the system has been pressurized, the leakage will be indicated by a pressure drop on the gauge.



TGB30
Top
Mount



TGB6



GP210-5



TGH30
Side
Mount

Gauge	Replacement Gauges	1/2" FPT		*Top Mount 3/4" FPT		1" FPT		Side Mount 3/4" FPT	
		Box	Display	Box	Display	Box	Display	Box	Display
**0-5 psi/in. ² -140" W.C. 360 mb [2.5" (63mm)]	GD308	TGB205	41302	TGB5	41355	TGB105	41402	TGH5	41458
15 psi, 2" 1/10 lb. incr. Full Scale	GP210-5	TGB215	41304	TGB15	41353	TGB115	41404	TGH15	41453
30 psi, 1/4 lb. incr., 2"	GP211-5	TGB230	41305	TGB30	41354	TGB130	41405	TGH30	41456
60 psi, 1 lb. incr., 2"	GP212-5	TGB260	41306	TGB60	41356	TGB160	41406	TGH60	41459
100 psi, 1 lb. incr., 2"	GP213-5	TGB2100	41303	TGB100	41352	TGB1100	41403	TGH100	41452
**0-6 psi/1/10 lb., 0-12 in. of Mercury, 4" [100mm]	GD408IP	TGB206	41307	TGB6	41357	TGB106	41407	TGH6	41460
0-15 psi/1/10 lb., 0-30 in. of Mercury, 4" [100mm]	GS410-51P	TGB4215	41308	TGB415	41358	TGB4115	41408	TGH415	41461

**Special sensitive 2 1/2" diaphragm gauge for more accurate low pressure reading.

*Uniweild reserves the right to use either plated steel or an aluminum hex body when supplying a top mount gas test gauge assembly.

Water Test Gauges

Part#	Description	Replacement Parts and Gauges	Description
TGW300	Water test gauge with 3/4" female hose connection, 2 1/2" gauge, 300 PSI	TGW	3/4" FHT x 3/4" female NPT connection only
TGW300DP	Water test gauge with 3/4" female hose connection, 2 1/2" gauge, 300 PSI Drag Pointer	GS316-5	2 1/2", 300 PSI, 12 o'clock dial
TGW160	Water Test gauge with 3/4" female hose connection, 2 1/2" gauge, 160 PSI	GS316-5DP	2 1/2", 300 PSI, 12 o'clock dial, Drag Pointer





Plastic and Steel Cased Utility Gauges

FOR U.S. JOBS
UNIWELD EMPLOYS OVER 300 WORKERS

Versatile, accurate and durable, these general purpose utility gauges are suitable for use on pressure media that are non-corrosive to brass or bronze. They are fitted with either bottom mount (BM) or center back mount (CBM) connections and are available in black plastic or black steel cases.

Pressure Range	1 1/2" Diameter				2" Diameter				2 1/2" Diameter	
	Black Steel Case		Black Plastic Case		Black Steel Case		Black Plastic Case		Black Steel Case	
	1/8" BM	1/8" CBM	1/8" BM	1/8" CBM	1/4" BM	1/4" CBM	1/4" BM	1/4" CBM	1/4" BM	1/4" CBM
	Part#	Part#	Part#	Part#	Part#	Part#	Part#	Part#	Part#	Part#
Hg PSI										
30" Hg+	GS100	GS150	GP100	GP150	GS200	GS250	GP200	GP250	GS300	GS350
30" Hg	GS108	GS158	-	-	GS208	GS258	-	-	GS308	GS358
30" - 15	GS101	GS151	-	-	GS201	GS251	-	-	GS301	GS351
30" - 30	GS102	GS152	-	-	GS202	GS252	-	-	GS302	GS352
30" - 60	-	-	-	-	-	-	-	-	GS303	GS353
30" - 100	-	-	-	-	-	-	-	-	GS304	GS354
30" - 150	-	-	-	-	GS205	GS255	-	-	GS305	GS355
PSI										
15	GS109	GS159	-	-	GS209	GS259	-	-	GS309	GS359
15+	GS110	GS160	GP110	GP160	GS210	GS260	GP210	-	GS310	GS360
.1 lb. incr.	-	-	-	-	GS210-5	-	GP210-5	-	-	-
30	GS111	GS161	GP111	GP161	GS211	GS261	GP211	-	GS311	GS361
.25 lb. incr.	-	-	-	-	GS211-5	-	GP211-5	-	-	-
60	GS112	GS162	GP112	GP162	GS212	GS262	GP212	-	GS312	GS362
1 lb. incr.	-	-	-	-	GS212-5	-	GP212-5	-	-	-
100	GS113	GS163	GP113	GP163	GS213	GS263	GP213	-	GS313	GS363
1 lb. incr.	-	-	-	-	GS213-5	-	GP213-5	-	-	-
160	GS114	GS164	GP114	GP164	GS214	GS264	GP214	GP264	GS314	GS364
200	GS115	GS165	GP115	GP165	GS215	GS265	GP215	GP265	GS315	GS365
300	GS116	GS166	GP116	GP166	GS216	GS266	GP216	GP266	GS316	GS366
400	GS117	GS167	GP117	GP167	GS217	GS267	GP217	GP267	GS317	GS367
600	GS118	GS168	-	-	GS218	GS268	-	-	GS318	GS368
1000	GS119	GS169	-	-	GS219	GS269	-	-	GS319	GS369
1500*	GS120	GS170	-	-	GS220	GS270	-	-	GS320	GS370
2000*	GS121	GS171	-	-	GS221	GS271	-	-	GS321	GS371
3000*	GS122	GS172	-	-	GS222	GS272	-	-	GS322	GS372
4000*	GS123	GS173	-	-	GS223	GS273	-	-	GS323	GS373
5000*	GS124	GS174	-	-	GS224	GS274	-	-	GS324	GS374
6000*	-	-	-	-	GS225	GS275	-	-	GS325	GS375



1/4" NPT • BM
2" diam. Black Steel Case



1/8" NPT • CBM
1 1/2" diam. Black Plastic Case



1/8" NPT • CBM
1 1/2" diam. Black Steel Case



1/4" NPT • BM
2 1/2" diam. Black Steel Case



GS243
RHT - Right Hand Thread
LHT - Left Hand Thread
Not for Oxygen service

NOTE: The following alternate options are available: [1] Stainless steel case in 1 1/2" or 2" diameter with CBM or BM connections. To order, change "GS" to "GSC". [2] Panel mount in black steel with posi-lock lens and CBM connections. To order, change "GS" to "PP"; [3] 1 1/2" "PP" gauge available with chrome plated ring. To order, change "GS" to "PC". We reserve the right to send dual scaled gauges. If dual scales required, add the suffix [-1] for PSI-kg/cm², [-2] for PSI-kPa [-3] for PSI-Bar. Many other options available. Call for more information. Shipped individually boxed. Add "D" to Part# for display card. Individually boxed gauges will have a UPC#, if requested.

2" High Pressure CO₂ Gauges Black Steel Case

2" High Pressure Gauge with red zone for gas order alert. For use with CO₂ or other compressed gases. 1/4" NPT.

Part#	UPC#	Description
GS241	51241	Bottom Mount [RHT] 3000 PSI
GS242	51242	Bottom Mount [LHT] 3000 PSI
GS243	51243	Side Mount [RHT] 3000 PSI
GS244	51244	Side Mount [LHT] 3000 PSI

UL Listed.



Uniweild Products, Inc. Fort Lauderdale, FL 33312 U.S.A. Customer Service: 800.323.2111
info@uniweild.com • www.uniweild.com

95

9 Gauges



Liquid Filled/Flowgauges/Medical Gauges

Liquid Filled Gauges

FOR U.S. JOBS
UNIWELD EMPLOYS OVER 300 WORKERS

Liquid fill (Glycerine) dampens the damaging effects of excessive vibration and pulsation while providing continuous lubrication of the internals; helping to prevent corrosion. Meets (A.N.S.I. B40.1) Grade B for accuracy. Normal operating pressure range is -14°F to 140°F.



2 1/2"
(63mm)
Gauge
1/4" NPT
Bottom
Mount

GSL311-3



G51D

Part#	UPC#	Pressure Range	Part#	UPC#	Pressure Range
GSL301-3	69103	30" Hg - 0 - 15 PSI [-1 - 0 - 1 Bar]	GSL316-3	69113	0 - 300 PSI [0 - 20 Bar]
GSL302-3	69104	30" Hg - 0 - 30 PSI [-1 - 0 - 2 Bar]	GSL317-3	69114	0 - 400 PSI [0 - 27 Bar]
GSL303-3	69105	30" Hg - 0 - 60 PSI [-1 - 0 - 4 Bar]	GSL318-3	69115	0 - 600 PSI [0 - 40 Bar]
GSL308-3	69106	30" Hg Vac. [0 to - 1 Bar]	GSL319-3	69118	0 - 1000 PSI [0 - 70 Bar]
GSL309-3	69107	0 - 15 PSI [0 - 1 Bar]	GSL320-3	69119	0 - 1500 PSI [0 - 100 Bar]
GSL311-3	69108	0 - 30 PSI [0 - 2 Bar]	GSL321-3	69120	0 - 2000 PSI [0 - 140 Bar]
GSL312-3	69109	0 - 60 PSI [0 - 4 Bar]	GSL322-3	69121	0 - 3000 PSI [0 - 200 Bar]
GSL313-3	69110	0 - 100 PSI [0 - 7 Bar]	GSL324-3	69122	0 - 5000 PSI [0 - 350 Bar]
GSL314-3	69111	0 - 160 PSI [0 - 11 Bar]	GSL325-3	69123	0 - 6000 PSI [0 - 400 Bar]
GSL315-3	69112	0 - 200 PSI [0 - 14 Bar]	GSL327-3	69124	0 - 10,000 PSI [0 - 700 Bar]

Flowgauges and Medical Gauges

Uniweld Flowgauges are designed for MIG and TIG welding applications. Uniweld Medical Gauges are designed for medical gas delivery systems in hospitals and in the home.



Green
Face with
White
increments

G55D

Part#	UPC#	Flow Gauges
G51D	54104	1 1/2" Gauges [1/8" NPT] Steel Case 40 SCFH, Argon, AR/CO ₂ MIX [75%-25%] Calibrated for 71 Dr./0.026 Orifice [60 PSI Max.]
G87D	54104	1 1/2" Gauges [1/8" NPT] Steel Case 10-40 SCFH, CO ₂ Calibrated for 71 Dr./0.026 Orifice [60 PSI Max.]
G76D	54217	2" Gauges [1/4" NPT] Brass Case 10-50 SCFH, AR/CO ₂ MIX [75%-25%] Calibrated for 67 Dr./0.032 Orifice [60 PSI Max.]
G77D	54219	2" Gauges [1/4" NPT] Brass Case 20-100 SCFH, CO ₂ Calibrated for 67 Dr./0.032 Orifice [60 PSI Max.]
G86D	54222	2" Gauges [1/4" NPT] Brass Case 10-50 SCFH, CO ₂ Calibrated for 69 Dr./0.029 Orifice [60 PSI Max.]
G76SD	54217	2" Gauges [1/4" NPT] Steel Case 10-50 SCFH, AR/CO ₂ MIX [75%-25%] Calibrated for 67 Dr./0.032 Orifice [60 PSI Max.]
G77SD	54219	2" Gauges [1/4" NPT] Steel Case 20-100 SCFH, CO ₂ Calibrated for 67 Dr./0.032 Orifice [60 PSI Max.]
G86SD	54222	2" Gauges [1/4" NPT] Steel Case 10-50 SCFH, CO ₂ Calibrated for 69 Dr./0.029 Orifice [60 PSI Max.]
G55D	54106	1 1/2" Gauges [1/8" NPT] Chromed Case 15 LPM, Plated Socket, Oxy Calibr. for 73 Dr./0.024 Orifice [60 PSI Max.]
G54D	54105	1 1/2" Gauges [1/8" NPT] Chromed Case, Plated Socket 4000 PSI.
G62D	54211	2" Gauges [1/8" NPT] Chromed Case 15 LPM, Plated Socket, Oxy Calibr. for 77 Dr./0.018 Orifice [120 PSI Max.]
G63D	54212	2" Gauges [1/8" NPT] Chromed Case, Plated Socket 4000 PSI.





Replacement Gauges/Lenses/Boots

Welding Gauges

FOR U.S. JOBS
UNIWELD EMPLOYS OVER 300 WORKERS



G15D



PSI Only



**PSI/Kg
Add (-1)
to Part#**



**PSI/kPa
Add (-2)
to Part#**

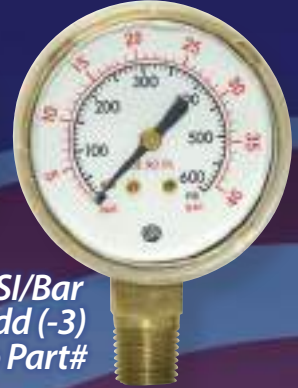

**PSI/Bar
Add (-3)
to Part#**

Pressure
Calibration

	1 1/2" GAUGES [1/8" NPT]			2" GAUGES [1/4" NPT**]			2 1/2" GAUGES [1/4" NPT**]	
	Powder Painted Steel Case B.M.	Gold Steel Case B.M.	Gold Steel Case C.B.M.	Brass Case B.M.	Brass Case C.B.M. <small>WITH WEEP HOLE</small>	Gold Steel Case B.M.	Brass Case B.M.	Gold Steel Case B.M.

15 PSI	-	G20D [BLUE]	-	-	-	-	-	-
30 PSI [Red Line 15-30]	G15D* (Red)	G79D*	-	G2D	-	G2SD	G22D	G22SD
30 PSI	-	G80D*	-	G74D	-	G74SD	G75D	G75SD
60 PSI	-	G83D*	-	G5D	G105	G5SD	G25D	G25SD
100 PSI	G49D* (Green)	G85D*	G185	G6D	G106	G6SD	G26D	G26SD
200 PSI	-	G78D*	G178	G4D	G104	G4SD	G24D	G24SD
300 PSI	-	G84D*	G184	G33D	-	G33SD	-	-
400 PSI	-	G73D*	-	G1D	G101	G1SD	G21D	G21SD
1/4, 1/2, 3/4 CONTENTS	G19D* (Red)	-	-	-	-	-	-	-
600 PSI	-	-	-	G8D	G108	G8SD	G28D	G28SD
1000 PSI	-	-	-	G34D	-	G34SD	-	-
4000 PSI, UL LISTED	G56D* (Green)	G82D*	G182	G7D	-	G7SD	G27D	G27SD
6000 PSI, UL LISTED	-	-	-	G44D	-	G44SD	G46D	G46SD

B.M. = Bottom Mount. C.B.M. = Center Back Mount. * With Gauge Boot.
** For 1/8" NPT add [-4] to Part Number.



**1 1/2"
Gauge
Boot Set
Black**

GB15S

Replacement Lenses



**GB20S
2"
Gauge
Boot Set
Black**

	Part#	1 1/2" Description	Part#	2" Description	Part#	2 1/2" Description
DISPLAY CARD	PL15	Posi-Lock	PL2	Posi-Lock	PL25	Posi-Lock
BULK	05-1-52	Flat Plastic	05-2-52-4	Flat Plastic	05-3-52-8	Posi-Lock
	05-1-52-7	Posi-Lock	05-2-52-7	Posi-Lock		
	05-1-63	Friction Ring	05-2-63-2	Friction Ring		



Uniweild Products, Inc. Fort Lauderdale, FL 33312 U.S.A. Customer Service: 800.323.2111
info@uniweild.com • www.uniweild.com

97

9 Gauges



Soft Solder and Self Fluxing Aluminum Alloys

FOR U.S. JOBS
UNIWELD EMPLOYS OVER 300 WORKERS

Uniweld's UNI-4300 aluminum soft solder kit with metal tip flux applicator is a great solution for the service technician who is frequently confronted with the task of repairing or joining aluminum to aluminum and aluminum to copper or brass. A common repair problem occurs when an air conditioning system's evaporator coil develops a small pinhole leak.

JOINS ALUMINUM, COPPER AND BRASS

UNI-4300 is an excellent product for this repair application due to its low melting point of 500 °F [260 °C] and 20,000 PSI tensile strength.

For best results, prepare the tubing by cleaning the surface and removing any oil, grease and oxides. To remove the oil and grease, use a chemical solvent. The oxides should be removed using only a stainless steel wire brush or emery cloth.

TUBING SURFACES MUST BE CLEAN.

When making a repair on an evaporator coil, it will be necessary to preheat the tubing prior to applying the flux. A common mistake when making this type of repair is to apply the flux and then begin heating the tubing. The evaporator coil disperses the heat and the tubing never reaches the melting temperature of the alloy. The flux then overheats and burns, then becomes an inhibitor that doesn't allow the alloy to bond properly to the base metal.

Preheat the evaporator tubing and then apply the flux using the metal tip flux applicator. Continue applying heat until the flux starts to bubble and then apply the UNI-4300 solder into the area being repaired.



P4KD9



P4KD9S



UNI-4200 Self Fluxing Aluminum Rods

Used for joining and repairing aluminum extrusions and castings. Also can be used for the manufacture and repair of aluminum doors and windows, repairing ladders, gutters, siding, aluminum boats and instrument boxes. Most kirkstone and zinc based dies can be repaired with this alloy. May also be used as wear-facing alloy on aluminum.



P3KH9

Part#	Description
P3KH9	UNI-4200 Self fluxing Aluminum rods
P4KD9S	UNI-4300 Aluminum solder [10 ft. coil] with a 2 oz. flux bottle & metal tip flux applicator
P4KD9	UNI-4300 Aluminum solder [10 ft. coil] with a 1 oz. flux bottle
F6CYAK	UNI-4300 2 oz. flux bottle
F6CYL	UNI-4300 1 oz. flux bottle



Silver Bearing Solder and Brazing Alloy



Alloys

FOR U.S. JOBS
UNIWELED EMPLOYS OVER 300 WORKERS

UNIBRITE 1450A

Acid Flux Cored Silver Bearing Solder

Uni-brite is a high strength acid core silver bearing soft solder. Free of cadmium, zinc, lead or antimony. Can be used on most alloys including copper, brass, stainless steel and nickel. A low working temperature of 430 °F [221 °C] eliminates weakening of the base metal caused by high heat brazing, resulting in greater overall strength of the components being joined.



Product	Description	Solidus Melting Point
B1KD9 UNIBRITE 1450A	1/16" X 10'	430 °F [221 °C]

UNI-1450 Soft Soldering Flux #F4CYG

A heavy duty liquid soft soldering flux that removes oxidation from surfaces to be soldered and improves wetting characteristics of the liquid solder.



F4CYG
4 oz.
Bottle

UNI-1000 Silver Brazing Flux #F19YJ

Use with Phos-Copper silver brazing alloys when joining dissimilar base metals such as Copper to Brass
Active Range:
1000 °F - 1800 °F
(538 °C - 982 °C)



F19YJ
7 oz. Jar



F28YF
3.5 oz. Jar

UNI-1500FC (Flux Coated) Low Fuming Bronze Brazing Alloy



UNI-1500FC

Superior wetting for complete tinning and general purpose brazing. Ideal for maintenance repairs on steel materials other than stainless steel. Use for fabricating and repair of galvanized sheets, pipes or angles. Tensile strength: 75,000 psi.

Uni-1500 Flux dissolves and removes oxides rapidly and thoroughly without bubbling and flows the filler metal into the joint freely and smoothly.

Product	1lb. Package		Solidus Melting Point
	3/32" X 18" Rod	1/8" X 18" Rod	
Uni-1500FC	C42F1	C42H1	1620 °F [882 °C]



Uniweled Products, Inc. Fort Lauderdale, FL 33312 U.S.A. Customer Service: 800.323.2111
info@uniweled.com • www.uniweled.com

99

10 Alloys

PART NUMBER INDEX

Part #	Page #	Part #	Page #	Part #	Page #	Part #	Page #
05-1-52	97	41406	94	48052	68	53650	50
05-1-52-7	97	41407	94	48053	68	53651	50
05-1-63	97	41408	94	48075	68	53652	50
05-2-52-4	97	41452	94	48800	68	53654	50
05-2-52-7	97	41453	94	48801	68	69901	93
05-2-63-2	97	41456	94	48802	68	69902	93
05-3-52-8	97	41458	94	48803	68	6N1RSD	81
10005	57,66	41459	94	48804	68	70000	88,89
10005-2	57	41460	94	48805	68	70001	88,89
10005-3	57	41461	94	48851	68	70002	89
100X51A4	57	42005	48	48852	68	70003	84
11482	92	42006	48	48853	68	70004	84
12106	37	42250	48	48854	68	70005	85
12107	37	42251	48	49000	70	70006	85
13401	71	42252	48	49001	70	70007	85
134A22-2A	57	42253	48	49002	70	70009	91
134A22A	57	42257	48	49003	70	70010	91
1393-3	57	42258	48	49004	70	70011	91
20N1RSD	81	42259	48	49005	70	70012	91
21085	62	42260	48	49006	70	70013	91
40000	74,75,76	42261	48	49007	70	70014	91
40001	74	42262	48	49008	70	70015	91
40002	74	42263	48	49009	70	70016	90
40003	74	42264	48	49010	70	70017	90
40004	74	42265	48	49011	70	70018	90
40022	75,77	42266	48	49016	72	70019	90
40039	74	42267	48	49020	70	70020	90
40040	74	42268	48	49021	70	70021	90
40045	75,77	42274	48	49022	70	70022	82
40048	75,77	42275	48	49023	70	70024	88,89
40049	72	42276	48	5005	4,5,6,7,8,9,10,11,12,13,41	70025	89
40050	75,77	42277	48	502	21,23,41	70027	89
40051	77	42278	48	503	10,41	70028	90
40052	77	42280	48	504	4,5,8,9,41	70029	89
40053	77	42281	48	510	11,12,41	70031	89
40054	77	42282	48	5-101-0	4,5	70032	89
40055	75	42283	48	5-101-00	16	70035	89
40061	74,75,76	42284	48	5-101-00D	16	70038	89
40062	76	42285	48	5-101-0D	16	70039	89
40063	76	42286	48	5-101-1	16	70040	89
40064	76	42288	48	5-101-1D	16	70041	85
40077	75	42289	48	5-101-2	4,16	70042	85
41302	94	42313	48	5-101-2D	16	70043	85
41303	94	45503	92	511	4,5,6,7,8,9,10,11,12,13,41	70044	85
41304	94	45506	92	512	21,23,29,41	70045	85
41305	94	45595	92	515	41,74	70046	85
41306	94	45596	92	516	41,74	70047	85
41307	94	45597	92	517	41	70048	85
41308	94	45598	92	5-200-0	11	70049	85
41352	94	45599	92	5-200-0D	16	70050	85
41353	94	46025	57	5-200-1	16	70051	85
41354	94	47827	68	5-200-1D	16	70052	85
41355	94	47850	68	5-200-2	16	70053	85
41356	94	47851	68	5-200-2D	16	70054	89
41357	94	47852	68	5-200M-0	11	70071	84
41358	94	47853	68	5-200M-0D	16	70072	83
41402	94	47880	71	5-200M-1	16	70074	82
41403	94	47881	71	5-200M-1D	16	70075	82
41404	94	48050	68	5-200M-2	16	70076	83
41405	94	48051	68	5-200M-2D	16	70078	80

PART NUMBER INDEX

Part #	Page #	Part #	Page #	Part #	Page #	Part #	Page #
70079	83	90050	63	90258	64	91654	69
70080	80	90051	63	90259	64	91861	45
70082	91	90052	63	90260	64	92655	60,61
70083	91	90053	63	90261	64	92786	73
70084	91	90054	63	90299	63	92788	73
70085	91	90055	63	90478	71	92795	73
70086	91	90059	70	90479	71	92797	73
70087	80	90060	72	90480	71	92799	71,
70089	80	90206	64	90481	71	92800	66,71
70090	88,89	90207	64	90482	71	92801	66,71
70091	88	90208	64	90483	71	92806	63
70121	80	90209	64	90484	71	92809	63
71	6,7,8,9,10,11,12,13,14,17,18,19,36	90210	64	90485	71	92810	63
89600	23	90211	64	90486	71	92811	63
89602	23	90212	64	90500	64	92816	66
89603	23	90213	64	90501	64	92817	66
89605	23	90214	64	90502	64	92818	66
89606	27	90215	64	90503	64	92820	66
89607	27	90216	64	90504	64	92822	49
89608	23	90217	64	90505	64	92825	49
89609	23	90218	64	90506	64	92829	49
89610	23	90219	64	90507	64	92830	73
89611	23	90220	64	90508	64	92832	49
89620	23	90221	64	90509	64	92833	63
89621	23	90222	64	90510	64	92835	49
89622	23	90223	64	90511	64	92836	66
89623	23	90224	64	90512	64	92838	49
89624	23	90225	64	90513	64	92863	66
89625	23	90226	64	90514	64	92867	49
89626	23	90227	64	90515	64	92868	49
89627	23	90228	64	90524	64	92869	49
89628	23	90229	64	90525	64	94170	73
89629	23	90230	64	90526	64	94175	73
90000	69	90231	64	90527	64	94180	72
90007	69	90232	64	90528	64	94184	51
90008	69	90233	64	90529	64	A-11	22,23
90009	69	90234	64	90530	64	A-14	22,23
90010	69	90235	64	90531	64	A-3	22,23
90027	70	90236	64	90532	64	A-32	22
90028	70	90237	64	90533	64	A-5	22,23
90029	70	90238	64	90534	64	A-8	5,9,22,23
90030	70	90239	64	90535	64	ABB134	66
90031	70	90240	64	90536	64	ABBRK	66
90032	70	90241	64	90537	64	AS-11	22,23
90033	70	90242	64	90538	64	AS-14	22
90034	70	90243	64	9059	39	AS-3	22,23
90035	70	90244	64	9059-2	39	AS-32	22
90036	70	90245	64	90691	71	AS-5	22,23
90037	70	90246	64	90750	69	AS-8	22
90038	70	90247	64	90751	69	ASQ21	25
90039	70	90248	64	90752	69	ASQ22	25
90040	70	90249	64	90753	69	ASQ23	25
90041	70	90250	64	91600	69	ASQ24	25
90042	70	90251	64	91601	69	ASQ25	25
90043	68,69,71	90252	64	91602	69	ASQ26	25
90044	68,69,71	90253	64	91603	69	ASQ27	25
90045	68,71	90254	64	91604	69	AT2	24
90046	68,71	90255	64	91651	69	AT3	24
90048	63	90256	64	91652	69	AT4	24
90049	63	90257	64	91653	69	ATQ2	24



PART NUMBER INDEX

Part #	Page #	Part #	Page #	Part #	Page #	Part #	Page #
ATQ3	24	EZM6B	61	G15D	36,37,95	G46D	97
ATQ4	24	EZM6R	61	G178	97	G46SD	97
AV25H	51	EZM6Y	61	G182	97	G49D	36,37,97
B	21,23,38,40,41,42	F10X	39	G184	97	G4D	97
B1KD9	99	F11	14	G185	97	G4SD	97
BG1	74,75,77	F13	5,9,14	G19D	36,37,95	G51D	96
BG1ACA	51	F19VJ	99	G1D	97	G529D	59
BG1FA	72	F22X	39	G1SD	97	G529LD	55,59
BV501FX	73	F24X	39	G20D	97	G529LD-5	59
C42F1	99	F25	39	G21D	97	G529LD-6	59
C42H1	99	F27L	39	G21SD	97	G529NBD	58
CA100	7,8,9,11,12,14,16	F27R	39	G22D	97	G529ND	58
CA550	4,5,11,14,16,36	F28	39	G22SD	97	G530D	59
CC61	43,67	F28VF	99	G24D	97	G530LD	55,59
CF25	58,59	F29L	39	G24SD	97	G530LD-5	59
CF80	58	F29R	39	G25D	97	G530LD-6	59
CH20	26	F31	39	G25SD	97	G530NBD	58
CH32	26	F32	39	G26D	97	G530ND	58
CT100-00D	16	F33	39	G26SD	97	G54D	96
CT100-0D	7,8,9,11,12,16	F34	39	G27D	97	G55D	96
CT100-1D	16	F35	39	G27SD	97	G56D	36,37,97
CT100-2D	16	F36	39,79	G28D	97	G5D	97
DHW316	82	F37	39	G28SD	97	G5S	97
EVX38	57	F38	39	G29D	59	G5SD	97
EZ100B	61	F41	39	G29D-1	59	G62D	96
EZ100R	61	F4CYG	99	G29D-5	59	G63D	96
EZ100Y	61	F50	39	G29LD	56,59	G6D	97
EZ25B	61	F58L	39,44	G29LD-1	59	G6SD	97
EZ25R	61	F58R	39,44	G29LD-5	59	G73-1D	97
EZ25Y	61	F59L	39	G29NBD	58	G73D	97
EZ353HS	61	F59R	39	G29NBD-1	58	G74D	97
EZ3B	61	F60	39	G29NBD-5	58	G74S	97
EZ3HS	61	F61X	39	G29ND	58	G74SD	97
EZ3R	61	F6CYAK	98	G29ND-1	58	G75D	97
EZ3Y	61	F6CYL	98	G29ND-5	58	G75SD	97
EZ50B	61	FB12	45	G2D	97	G76D	96
EZ50R	61	FG24A	51	G2SD	97	G76SD	96
EZ50Y	61	FL34	4,5,6,7,8,9,10,11,12,13,43,67	G30D	59	G77D	96
EZ5B	61	FL3437	43	G30D-1	59	G77SD	96
EZ5HDS	61	FL3437TC	43	G30D-5	59	G78D	97
EZ5HS	61	FL34D	43	G30LD	56,59	G79-4D	97
EZ5R	61	FL35	43	G30LD-1	59	G79D	97
EZ5Y	61	FL36	43	G30LD-5	59	G7D	97
EZ6B	61	FL37	43	G30NBD	58	G7SD	79,97
EZ6HS	61	FV600	36	G30NBD-1	58	G80D	97
EZ6R	61	FVX38	57	G30NBD-5	58	G82-1D	97
EZ6Y	61	FY10X	39	G30ND	58	G82D	97
EZAB	61,66	FY10XA	39	G30ND-1	58	G83D	36,78,97
EZAB90	61,66	FY10XAV	39	G30ND-5	58	G84D	78,97
EZABM	61,66	FY10XV	39	G33D	97	G85-1D	97
EZABM90	61,66	FY11X	39	G33SD	97	G85D	97
EZABR90	61,66	FY11XA	39	G34D	97	G86D	96
EZHR	61	FY11XAV	39	G34SD	79,97	G86SD	96
EZHRK	61,66	FY11XV	39	G409NSAD	58,70	G87D	96
EZM3B	61	G101	97	G410NSAD	58,70	G8D	97
EZM3R	61	G104	97	G429ND	52,53,54,58	G8SD	79,97
EZM3Y	61	G105	97	G429ND-5	58	G9LAD	59,70
EZM5B	61	G106	97	G430ND	52,53,54,58	G9LD-5	59
EZM5R	61	G108	97	G430ND-5	58	GB15S	37,97
EZM5Y	61	G10LD-5	59	G44D	97	GB20S	79,97
		G10LAD	59,70	G44SD	97	GB25S	58,59

PART NUMBER INDEX

Part #	Page #	Part #	Page #	Part #	Page #	Part #	Page #
GB805	58	GS152	95	GS267	95	GSL302-3	96
GD308	94	GS158	95	GS268	95	GSL303-3	96
GD408IP	94	GS159	95	GS269	95	GSL308-3	96
GP100	95	GS160	95	GS270	95	GSL309-3	96
GP110	95	GS161	95	GS271	95	GSL311-3	96
GP111	95	GS162	95	GS272	95	GSL312-3	96
GP112	95	GS163	95	GS273	95	GSL313-3	96
GP113	95	GS164	95	GS274	95	GSL314-3	96
GP114	95	GS165	95	GS275	95	GSL315-3	96
GP115	95	GS166	95	GS300	95	GSL316-3	96
GP116	95	GS167	95	GS301	95	GSL317-3	96
GP117	95	GS168	95	GS302	95	GSL318-3	96
GP150	95	GS169	95	GS303	95	GSL319-3	96
GP160	95	GS170	95	GS304	95	GSL320-3	96
GP161	95	GS171	95	GS305	95	GSL321-3	96
GP162	95	GS172	95	GS308	95	GSL322-3	96
GP163	95	GS173	95	GS309	95	GSL324-3	96
GP164	95	GS174	95	GS310	95	GSL325-3	96
GP165	95	GS200	95	GS311	95	GSL327-3	96
GP166	95	GS201	95	GS312	95	GT512-2	93
GP167	95	GS202	95	GS313	95	GT562-2	93
GP200	95	GS205	95	GS314	95	GT565	93
GP210	95	GS208	95	GS315	95	GT566	93
GP210-5	94,95	GS209	95	GS316	95	GT568	93
GP211	95	GS210	95	GS316-5	95	GT570	93
GP211-5	94,95	GS210-5	95	GS316-SDP	95	H012A400A	65
GP212	95	GS211	95	GS317	95	H012A409A	65
GP212-5	94,95	GS211-5	95	GS318	95	H012A410A	65
GP213	95	GS212	95	GS319	95	H018A400A	65
GP213-5	94,95	GS212-5	95	GS320	95	H018A409A	65
GP214	95	GS213	95	GS321	95	H018A410A	65
GP215	95	GS213-5	95	GS322	95	H02-3	26,67
GP216	95	GS214	95	GS323	95	H024A400A	65
GP217	95	GS215	95	GS324	95	H024A409A	65
GP250	95	GS216	95	GS325	95	H024A410A	65
GP264	95	GS217	95	GS350	95	H030A400A	65
GP265	95	GS218	95	GS351	95	H030A409A	65
GP266	95	GS219	95	GS352	95	H030A410A	65
GP267	95	GS220	95	GS353	95	H036A400A	65
GS100	95	GS221	95	GS354	95	H036A409A	65
GS101	95	GS222	95	GS355	95	H036A410A	65
GS102	95	GS223	95	GS358	95	H048A400A	65
GS108	95	GS224	95	GS359	95	H048A409A	65
GS109	95	GS225	95	GS360	95	H048A410A	65
GS110	95	GS241	95	GS361	95	H060A400A	65
GS111	95	GS242	95	GS362	95	H060A409A	65
GS112	95	GS243	95	GS363	95	H060A410A	65
GS113	95	GS244	95	GS364	95	H06A404A	49
GS114	95	GS250	95	GS365	95	H065MBB	60
GS115	95	GS251	95	GS366	95	H065MBR	60
GS116	95	GS252	95	GS367	95	H065MBY	60
GS117	95	GS255	95	GS368	95	H1005MBB	60
GS118	95	GS258	95	GS369	95	H1005MBEB	62
GS119	95	GS259	95	GS370	95	H1005MBER	62
GS120	95	GS260	95	GS371	95	H1005MBEY	62
GS121	95	GS261	95	GS372	95	H1005MBB	60
GS122	95	GS262	95	GS373	95	H1005MBR	60
GS123	95	GS263	95	GS374	95	H1005MBY	60
GS124	95	GS264	95	GS375	95	H11	35
GS150	95	GS265	95	GS410-SIP	94	H11B	35
GS151	95	GS266	95	GSL301-3	96	H12	21,23,24,25,35



PART NUMBER INDEX

Part #	Page #	Part #	Page #	Part #	Page #	Part #	Page #
H12B	35	H6SMBEB	62	HLP10	35	K55CM	39
H13	35	H6SMBER	62	HLP10B	35	K55CP	39
H13B	35	H6SMBEY	62	HLP10SS	30,35	K56C	11
H1476	60	H6SMBR	60	HLP11	35	K56C-T	11
H15MBB	60	H6SMBY	60	HLP11B	35	K80	30
H15MBR	60	H765-10	60,73	HLP11BS	35	K83	30
H15MBY	60	H8SMBB	60	HLP11BSS	35	KC100	12
H25SMBB	60	H8SMBEB	62	HLP11S	35	KC100C	12
H25SMBEB	62	H8SMBER	62	HLP11SS	31,35	KC100CT	12
H25SMBER	62	H8SMBEY	62	HLP13	35	KC100FC	12
H25SMBEY	62	H8SMBR	60	HLP13B	35	KC100P	12
H25SMBR	60	H8SMBY	60	HLP13BS	35	KC100PT	12
H25SMBY	60	HCO1	39	HLP13BSS	35	KC122L	12
H2P100D	72	HCO2	39	HLP13S	35	KC122P	12
H2SMBB	60	HC353SMB	60	HLP13SS	35	KCA110	31
H2SMBR	60	HC353SMBE	62	HLP14	35	KCA111	31
H2SMBY	60	HC3SMB	60,61	HLP14B	27,28,29,35	KL22	7
H2SSM	51,74,75,77	HC3SMBE	62	HLP14BS	35	KL22C	7
H32A	4,5,6,7,8,9,10,11,12,13,35,36	HC4SMB	60,61	HLP14BSS	35	KL22C-T	7
H32AB	35	HC4SMBE	62	HLP14S	35	KL22P	7
H32ABT	35	HC5SMBE	62	HLP14SS	35	KL22P-T	7
H32AT	12,35,36	HC6SMBE	62	HN82A	39	KL550-4	4
H32B	35	HCC38	44	HN83A	39	KL550-4C	4
H32BT	35	HCC38-0	44	HN83P	39	KL550-4C-T	4
H33A	35	HCC39	29,44	HN84	39	KL550-4P	4
H33AB	35	HCC39-0	44	HN87	39	KL550-4P-T	4
H33B	35	HCC40	39	HR134N-10	70,73	KL550-5	4
H34A	35	HCC41	39	HR134N-100	70	KL550-TR	4
H34B	35	HCC46	39	HS53	39	KL555-TR	4
H3D25M	64	HCC47	39	HS54	39	KL71-4	8
H3D3M	64	HCC78	39	HS55	39	KL71-4C	8
H3D4M	64	HCC79	39	HT44	33	KL71-4C-T	8
H3D50M	64	HD018A700A	65	HT44TE	33	KL71-4P	8
H3D5M	64	HD018A709A	65	HVP12	46,48	KL71-4P-T	8
H3D6M	64	HD018A710A	65	HVP12RK	48	KL71-5	8
H3D8M	64	HD030A700A	65	HVP6	46, 48	KL71-5TR	8
H3SMBB	60	HD030A709A	65	HVP6RK	48	KLC100	12
H3SMBEB	62	HD030A710A	65	HVP8	46,48	KLC100C	12
H3SMBER	62	HD1A700A	65	HVP8RK	48	KLC100CT	12
H3SMBEY	62	HD1A709A	65	HX14N-10	60,61,73	KLC100P	12
H3SMBR	60	HD1A710A	65	HX14N-100	60	KLC100PT	12
H3SMBY	60	HD1X14N-10	65	K22	6	KLPT4	28
H4SMBB	60	HD2A700A	65	K22C	6	KLPTQ4	28
H4SMBEB	62	HD2A709A	65	K22C-T	6	KLT550-4	5
H4SMBER	62	HD2A710A	65	K22P	6	KLT550-4C	5
H4SMBEY	62	HD3A700A	65	K22P-T	6	KLT550-4C-T	5
H4SMBR	60	HD3A709A	65	K23	10	KLT550-4P	5
H4SMBY	60	HD3A710A	65	K23C	10	KLT550-4P-T	5
H50SMBB	60	HD4A700A	65	K23C-T	10	KLT550-5	5
H50SMBEB	62	HD4A709A	65	K23P	10	KLT550-5TR	5
H50SMBER	62	HD4A710A	65	K23P-T	10	KL71-4	9
H50SMBEY	62	HD5A700A	65	K24	10	KL71-4C	9
H50SMBR	60	HD5A709A	65	K24TB	10	KL71-4C-T	9
H50SMBY	60	HD5A710A	65	K37	27,28,29,35	KL71-4P	9
H55MBB	60	HDCSMB	60	K38	35	KL71-4P-T	9
H55MBEB	62	HDCSMB A	61	K40	35	KL71-5	9
H55MBER	62	HDX14N-10	64	K41	35	KL71-5TR	9
H55MBEY	62	HFX12-10	64	K45CM	35	KQ37	25
H55MBR	60	HFX14-10	65	K45CP	39	KQ38	25
H55MBY	60,74,75	HFX38-10	64,65	K46P	39	KT2A5	21
H6SMBB	60	HG4	45	K46P-T	39	KT2A5MC	21

PART NUMBER INDEX

Part #	Page #	Part #	Page #	Part #	Page #	Part #	Page #
KT2A5MCT	21	Q422A	57	RMC2	6,7,8,9,10,11,36	ST07MP	31
KT2A5T	21	Q4N8	53	RO	6,7,8,9,10,11,36	ST07RSM	31
KTA23	24	Q4N85SM	53	RO100	12,13,37	T-2	27
KTA23MC	24	Q4N85SMEZ	53	ROB	36	T2A-12	20
KTA3	24	QA200A	57	RP3A	11,12,30,31,36	T2A-12TE	20
KTA34	24	QAL	56	RP3B	29,31	T2A-3	20
KTA3MC	24	QAL35M	56	RP3E	31,32	T2A-3TE	20
KTAQ23	24	QAL35MEZ	56	RP3T2	32	T2A-5	20,21
KTAQ23MC	24	QAL55M	56	RP3T3	32	T2A-5TE	20
KTAQ3	24	QAL55MEZ	56	RP3T4	32	T2A-8	20
KTAQ34	24	QAL65M	56	RP3T5	32	T2A-8TE	20
KTAQ3MC	24	QAL65MEZ	56	RP3T6	33	T-3	27
KTS2	29	QS4L	55	RSB2	4,5,37	T-4	27
KTSQ2	29	QS4L3H	55	RSB2B	37	T-5	27
LD32	26,67	QS4L5HBV	55	RSDBIT1	81	TCJD	42
LD7-1A	67	QS4L3HEZ	55	RSDBIT2	81	TCLD	42
LDPLC	67	QS4L5H	55	RSDBIT3	81	TCMD	42
LPT4	28,29	QS4L5HBV	55	RSDBIT4	81	TCPD	42
LPT5	28	QS4L5HEZ	55	RSDBIT5	81	TCSD	42
LPT6	28	QS4L6H	55	RSDBIT6	81	TCV10	44
LPTQ4	28,29	QS4L5HBV	55	RSDBIT7	81	TCV100	44
LPTQ5	28	QS4L6HEZ	55	RSDBIT8	81	TCV101	44
LPTQ6	28	QS8N	54	RSMC2	4,5,37	TCV11	44
MC 4,5,6,7,8,9,10,11,12,13,21,23,36,38,40,41,42		QS8N3SMEZ	54	RSMC2B	37	TCVA	44
†MDC	40	QS8N5SMEZ	54	RSO	4,5,37	TCVB	44
†MKT-4L	32	QS8N6SMEZ	54	RSOB	37	TFA100	44
MTF-5	6,7,19	QVK-2	57	RTB118	90	TFA101	44
MTF-9	19	R	4,5,6,7,8,9,10,11,12,13,40,41	RTBCA118	90	TFAA	44
MTF-17	19	R1346	79	RTBCA58	90	TFAB	44
MTFM-5	19	R1349	79	RTBCA78	90	TFAM100	44
MTFM-9	19	R1358	79	RTBM118	90	TFAM101	44
MTFM-17	19	R1360	79	RTBM12	90	TGB	94
MTR	18	R1362	79	RTBM34	90	TGB1	94
MTT	12,18	R1363	79	RTBM38	90	TGB100	94
MTW-1	18	R1546	79	RTBM58	90	TGB105	94
MTW-2	12,18	R1549	79	RTBM78	90	TGB106	94
MW2	57	R1558	79	RTBR	90	TGB1100	94
N20	40	R1560	79	RTBRC	90	TGB115	94
N40	40	R1562	79	S21	25	TGB130	94
N60	40,41	R1563	79	S22	25,26	TGB15	94
NV1	78	R40	40,41	S23	25	TGB160	94
P3KH9	98	R96K	78	S24	25	TGB2	94
P4KD9	98	RB	21,23,24,25,36,38	S25	25	TGB205	94
P4KD9S	98	RB2	8,9,10,36	S26	25	TGB206	94
PB29	26	RB2B	8,9,10	S27	25	TGB2100	94
†PCLD33	67	RCV100	44	S28	26	TGB215	94
†PCLD33T	67	RCV101	44	SC180	62	TGB230	94
PCV	67	RCVB	44	SC45	62	TGB260	94
PCV25	32	RFA100	44	SC90	62	TGB30	94
†PDC	40	RFA101	44	SCFHB	62	TGB4115	94
PL15	97	RFAA	44	SCFHR	62	TGB415	94
PL2	97	RFAB	44	SCFHY	62	TGB4215	94
PL25	58,59,97	RFAM100	44	SHLP	30,31,35	TGB5	94
PLD33	67	RFAM101	44	SM36	30	TGB6	94
PLD33V	67	RHP400	75,79	SM38	30	TGB60	94
PUA	14	RHP500	79	SPR3A	57	TGCB	40
Q408A	57	RHP800	79	SPR3K	57	TGCMC	40
Q414K	57	RLP	36	SS37	26	TGCN	40
Q422-2A	57	RLPB	27,28,36	SS38	26	TGCO	40
Q422-3A	57	RMC	21,23,24,25,36,38	ST06MP	31	TGH	94
Q422-4A	57	RMC100	12,13,37	ST07A	26,31	TGH100	94



PART NUMBER INDEX

Part #	Page #	Part #	Page #	Part #	Page #	Part #	Page #
TGH15	94	TYPE13E-8	17	TYPE28TE-2	17	UTC701	86,87
TGH30	94	TYPE17-0	8,10,12,13,16	TYPE28TE-4	17	UTC702	86,87
TGH415	94	TYPE17-00	16	TYPE28TE-6	17	UTC703	86,87
TGH5	94	TYPE17-000	16	TYPE28TE-8	17	UTC704	86,87
TGH6	94	TYPE17-1	8,16	UM17-0	16	UTC705	86,87
TGH60	94	TYPE17-15	4,5,17	UM17-000	16	UTC706	87
TGV	94	TYPE17-2	4,5,6,7,8,9,10,11,12,13,16	UM17-2	16	UVP1.5-110	47,48
TGW	94	TYPE17-3	11,12,16,36	UM17-3	16	UVP1.5-220	47,48
TGW160	94	TYPE17-30	17	UM17-4	16	UVP5	47,48
TGW300	94	TYPE17-4	16	UM17-5	16,17,18	UVP5-220	47,48
TGW300DP	94	TYPE17-5	16	UNF3	78	VP87	48
TH3	23,25,30,34	TYPE17-6	16	UNF93A	78	VP86	48
TH3B	27,34	TYPE17-7	16	UPA	14	VV1	51
TH5	24,34	TYPE17-9	17	USAM	52	VV1A	51
TH5B	28,29,34	TYPE17E-0	16	USAM3EZ	52	W05	4,5,6,7,8,9,10,11,12,13,21,23,24,25,42
TH6	21,23,25,34	TYPE17E-00	16	USAM5EZ	52	W06	42
TH6B	27,34	TYPE17E-000	16	USAM6EZ	52	W10X	42
TH7	24,34	TYPE17E-1	16	USAM3BV	52	W94	42
TH7B	28,29,34	TYPE17E-2	16	USAM5BV	52	WB500	29
TH8	34	TYPE17E-3	16	USAM6BV	52	WG52	42
TH8B	34	TYPE17E-4	16	USP8E	15	WG53	4,5,6,7,8,9,10,11,12,13,42
TH9	25,30,31,34	TYPE17E-5	16	USP8F	15	WH550	4,5,14,17,18,19
TH9B	34	TYPE17E-6	16	USP8S	15	X09R	38,71,73
TS-2	27	TYPE17E-7	16	USP8A	15	X11R	71,73
TS-3	27	TYPE17E-9	17	UT2	31,32	X15R	73
TS-4	27	TYPE17TFT	18	UT3	31,32	X25R	16
TS-5	27	TYPE28-2	17	UT4	31,32	X26R	16
TUA	34	TYPE28-4	17	UT5	31,32	X40R	73
TXRK	16	TYPE28-6	17	UT6	31,33		
TYPE13-8VM	17	TYPE28-8	17	UTA	34		



Contact Information

WORLD HEADQUARTERS UNIWELED PRODUCTS, INC.

2850 Ravenswood Road
Fort Lauderdale, Florida 33312
954.584.2000 • FAX: 954.587.0109
800.323.2111 • www.uniweld.com
email: info@uniweld.com

HOUSTON WAREHOUSE UNIWELED PRODUCTS, INC.

South Loop Business Park
6121 Long Drive
Houston, TX 77087-2008
800.323.2111
FAX: 954.587.0109

CANADIAN WAREHOUSE METRO UNIWELED PRODUCTS, LTD.

Metro Uniweld
Eastern Canadian Warehouse
5150 Timberlea Blvd.
Mississauga, ON L4W 2S5
800-472-3129
FAX: 800-511-4940

Metro Uniweld
Western Canadian Warehouse
#11-3603 Millar Avenue
Saskatoon, SK S7P 0B2
800-472-3129
FAX: 800-511-4940

SOUTH AMERICAN OFFICE & FACTORY UNIWELED ANDINA

Porfirio Romero OE1-58
y Avda. 10 de Agosto
Quito Ecuador S.A.
TEL: 593 2 241 5446
FAX: 593 2 240 4494
email: cliente@uniweld.com.ec

MIDDLE EAST & AFRICA - REGIONAL OFFICE UNIWELED PRODUCTS, INC.

Dakkash Street
Palm Bldg. 8th Floor
P.O. Box 13/5601
Beirut, Lebanon
TEL: 00 961 3 732 961
FAX: 00 961 1 557 475
email: unimideast@uniweld.com





Flame Tools Safety Training



North American Technician Excellence (NATE), headquartered in Arlington, VA, was founded in 1997 and is the nation's largest non-profit certification organization for heating, ventilation, air conditioning and refrigeration technicians. NATE is the only technician certification organization governed, owned, operated, developed and supported by the HVACR industry.

COURSE NAME: FLAME TOOLS SAFETY TRAINING

NATE COURSE# 6111-0001

CONTINUING EDUCATION HOURS (CEH): 2 HOURS

COURSE OVERVIEW: A field training course that last approximately 2 hours with lecture/discussion and demonstrations.

REQUIRED TOPICS:

- **Introduction Overview** of Uniweld Products, Inc.
- **Fire Triangle** - A review of the Fire Triangle and the basic elements of fire.
- **Fuel Gases and Cylinders** - General discussion on the different types of fuels used to braze and solder copper tubing. Working temperatures of the various fuels and their applications. Safety precautions when working with the various fuel gases and cylinders.
- **Flame Tools** - A review of oxyacetylene and air-fuel flame tools and their applications within the HVACR, Plumbing and Maintenance industries.
- **Flame Tool Set Up and Safety** - Step by step procedure on setting up an oxyacetylene outfit and the proper safety procedures to apply when in use. This will include a review on setting the regulator delivery pressures based on the tip size used, proper procedures on shutting down an oxyacetylene outfit and preparing it for storage.
- **Alloys** - Review of the various alloys used in soldering/brazing, including aluminum alloy.
- **Nitrogen Regulators and Flow Indicators** - Review the use of nitrogen when purging an AC or R system and the effective way to monitor nitrogen flow.
- **Brazing Demonstration** - Review capillary action of brazing alloy with proper brazing techniques and which flame tool to use in certain applications.

All attendees must sign a NATE Official Recognized Provider Attendance Record.

This course applies to the following NATE course outlines:

SERVICE		INSTALLER	
ACSV	Air Conditioning – Air to Air	ACIN	Air Conditioning – Air to Air
HPSV	Heating – Reverse Cycle Air to Air	HPIN	Heating – Reverse Cycle Air to Air
RLSV	Light Commercial Refrigeration	RLIN	Light Commercial Refrigeration
RCSV	Commercial Refrigeration		

NATE is a registered trademark of the North American Technician Excellence, Inc.





Marketing / Sales Aids



**English
Safety Poster
Part #USP8E**

**Spanish
Safety Poster
Part #USP8S**



SAFETY POSTERS



**French
Safety Poster
Part #USP8F**

**Arabic
Safety Poster
Part #USPA**





Marketing / Sales Aids



BANNER

Vinyl Banner 38" x 27" with Grommets
Part # BANNER



DISTRIBUTOR DECALS

English Part #L002E
Spanish Part #L002S



Digest Size
5.5" X 7"

Part #UGACATD

Standard Size
8.5" X 11"

Part #UGACAT

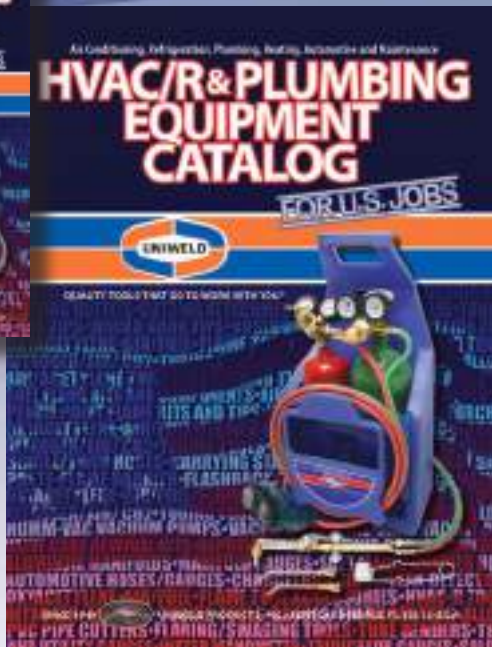

CATALOGS



UNIWELO CAP

Part #UNIWELODCAP





Marketing / Sales Aids

UniWeld merchandising display materials help organize product selection to stimulate interest and entice technicians to make a purchase. The UniWeld headers, vinyl pegboard and slatwall covers can be applied to existing floor displays or wall mounted materials. Contact your local UniWeld representative to order and setup your merchandising display today!

SLATWALL COVERS

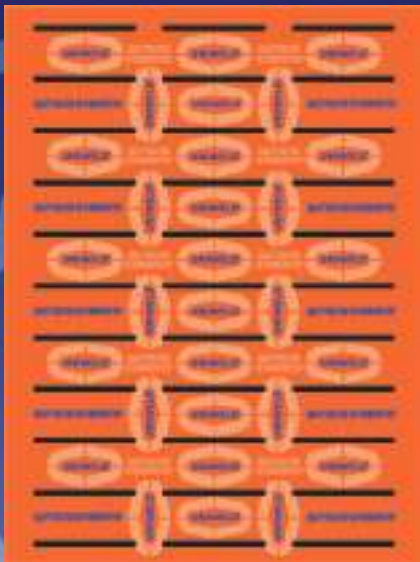

(24" x 32")

Part # UWVSWC Slatwall Vinyl Cover w/tape

PEGBOARD COVERS

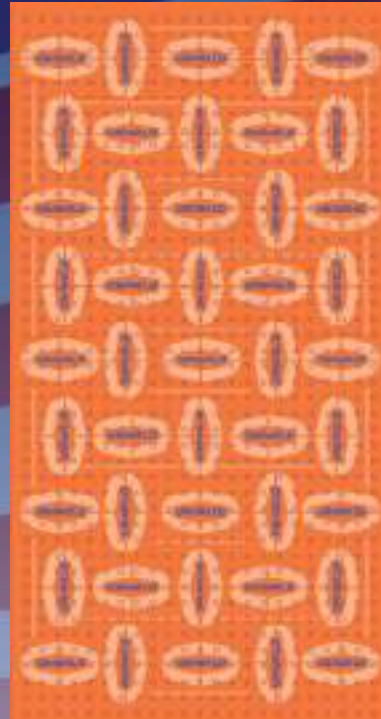

(24" x 47")

Part # UWVPC Pegboard Vinyl Cover with Black Plastic Cover Pegs (6 per Cover)

Part # PHCH Black Plastic Cover Pegs

UNIWELD HEADERS



(24.5" x 8.5")

Part # UWGH Gondola Header w/2-Self Stick Clips

Part # UWPH Pegboard Header w/Black Button Pegs

Part # UWSWH Slatwall Header w/Double Sided Tape

Part # UWSH Spinner Header

REORDER TAG



Part # XFST



UniWeld Products, Inc. Fort Lauderdale, FL 33312 U.S.A. Customer Service: 800.323.2111
info@uniweld.com • www.uniweld.com



Marketing / Sales Aids

MERCHANDISING SPINNER DISPLAY



Part # SPINNER

- Measuring 24" (W) x 61" (H), this display has three pegboard sides and fully rotates.
- Features attractive, durable orange and blue Uniweld logo vinyl pegboard covers and header sign.
- Includes: (25) 4" Pegboard Hooks, (10) 8" Pegboard Hooks, (50) Reorder Tags, Authorized Distributor Decals and instructions.
- Products sold separately
- Contact your local Uniweld representative and order your Merchandising Spinner display today!



112



Uniweld Products, Inc. Fort Lauderdale, FL 33312 U.S.A. Customer Service: 800.323.2111
info@uniweld.com • www.uniweld.com



UniWeld Products, Inc. Fort Lauderdale, FL 33312 U.S.A. Customer Service: 800.323.2111
info@uniweld.com • www.uniweld.com



Marketing / Sales Aids

MERCHANDISING GONDOLA DISPLAY



Part # GONDOLA

- Measuring 48" (L) x 54" (H) x 12" (W) display with base shelf.
- Features attractive, durable orange and blue Uniweld logo vinyl pegboard covers and header sign.
- Includes: (25) 4" Pegboard Hooks, (10) 8" Pegboard Hooks, (50) Reorder Tags, Authorized Distributor Decals and instructions.
- Products sold separately
- Contact your local Uniweld representative to order and setup your Merchandising Gondola display today!



Uniweld Products, Inc. Fort Lauderdale, FL 33312 U.S.A. Customer Service: 800.323.2111
info@uniweld.com • www.uniweld.com

HVAC/R & PLUMBING EQUIPMENT CATALOG

Since 1949, Uniweld, a U.S. Manufacturer, has employed over 300 workers who help design, manufacture, and distribute U.S. made products to be sold worldwide! As we celebrate 65 years of manufacturing excellence, our focus is ever set on the future to provide a superior product coupled with unmatched customer service. Uniweld's World Headquarters and manufacturing facility based in Ft. Lauderdale, FL has state of the art robotic CNC machines that produce quality flame tools, accessories, and pressure gauges for the air conditioning, refrigeration, plumbing, heating, automotive and maintenance industries. We thank you for supporting Uniweld Product.

FOR U.S. JOBS



QUALITY TOOLS THAT GO TO WORK WITH YOU®

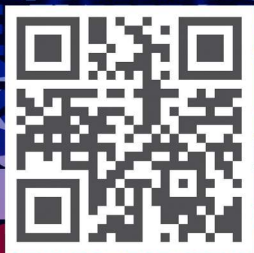

FOLLOW US



UNIWELD PRODUCTS, INC.

2850 Ravenswood Road, Fort Lauderdale, FL 33312 U.S.A.

800.323.2111 • 954.584.2000 • Fax: 954.587.0109 • info@uniweld.com

www.uniweld.com

UGA/CAT 6/14